

KRMG Kiosk Printer

SERIAL & PARALLEL IEEE1284 INTERFACE

USER'S MANUAL

Reference : 31 08 212 Z

December 2004



IMPORTANT

This manual contains the basic operations for running your printer.

Read it carefully before using your printer.

Pay special attention to the chapter “Recommendations”.

EVOLUTIONS		
-------------------	--	--

Date	Issue	Modifications
12/04	Z	Creation

CONTENTS

1. OVERVIEW	5
2. MECHANICAL SPECIFICATIONS	7
2.1. OVERALL DIMENSIONS – PAPER EXIT POSITION	7
2.2. FIXING POINTS POSITION	8
2.3. NOTES:	8
3. RECOMMANDATIONS	10
3.1. GENERAL MECHANICAL INTEGRATION:	10
3.2. PAPER EXIT PROTECTION:	10
3.3. GROUNDING:	10
3.4. POWER SUPPLY:	10
3.5. PAPER SETTING:	10
4. BOARD CONNECTION	11
4.1. POWER SUPPLY CONNECTOR (FEMALE)	11
4.2. DATA CONNECTOR DESCRIPTION	11
5. PROTOCOL COMMUNICATION	12
5.1. COMMUNICATION PORT PARAMETERS	12
5.2. IEEE 1284 COMMUNICATION	12
5.2.1. <i>Compatibility Mode</i>	14
5.2.2. <i>Nibble Mode Negotiation and Transfer</i>	14
5.2.3. <i>Timing</i>	15
5.3. RS 232 COMMUNICATION	15
5.3.1. <i>XON/XOFF Protocol</i>	16
5.3.2. <i>DTR/DSR Protocol</i>	16
6. GENERAL PCB SPECIFICATIONS	17
7. LIST OF CONTROL CODES	18
8. COMMAND DESCRIPTION	21
8.1. PRINT COMMANDS	21
8.2. LINE SPACING	23
8.3. PRINT POSITION	24
8.4. CHARACTER CONTROL	27
8.5. BIT IMAGE	35
8.6. BAR CODE	37
8.7. STATUS	40
8.8. MECHANISM CONTROL	41
8.9. FLASH DOWNLOAD	42
8.10. OTHER COMMANDS	46
9. SELF TEST TICKET DESCRIPTION	51
10. TROUBLESHOOTING	52
10.1. PRINTING PROBLEMS	52
10.2. PRINTER DOES NOT FUNCTION	52

1. OVERVIEW

Based on static thermal printing technology, the KRMG series is a family of user-friendly, highly reliable devices which have been specially designed to simplify the integration of the mechanism and PCB.

A strong metal frame easy to fix to the host application contains both the mechanism and the PCB. The main features are: a paper roller holder with un-losable axle activated by a lever, an adjustable low paper sensor and a paper feed button.

KRMGxx00: Kiosk Printer with serial interface.

KRMGxx30: Kiosk printer with parallel interface

Characteristics:

Guillotine cutter allowing full or partial cuts

8 dots/mm print-heads (203 dpi)

Paper roll up to 120mm diameter (3.72 inches)

SUMMARY OF PRINTER SPECIFICATIONS

ITEM	VALUE	UNITS
Printing method	Static thermal dot line printing	-
Printing width	48	mm
Printing speed	80	mm/sec
Paper loading	Lever & axle for roll, Auto-load for paper end	-
Paper width	60	mm
Paper empty detection	By opto-sensor	-
Maximum paper thickness	80	μ
Recommended paper	2320061 / KP 440 (60μ)	AXIOHM reference / Kanzan
Number of resistor dots	384	-
Resolution	8	dots/mm
Paper feed / dot line	0.125	mm
Head temperature detection	By Thermistor	-
Out of paper detection	Opto-sensor	-
Maximum duty cycle (to avoid motor temperature rise) (Max 2 "On")	40 (see chapter recommendations)	%
Maximum Number of Printable Characters per Line	24 characters <i>default</i> (16x24 dot font, character spacing 4 dots) 42 characters (9x24 dot font, character spacing 2 dots)	-
Max roll Ø *	120	mm

*: See mechanical dimension as the biggest possible roll protrudes outside the kiosk

SUMMARY OF PRINTER SPECIFICATIONS (continued)

ITEM		VALUE	UNITS
Storage temperature range		- 20 to + 60	°C
Operating temperature range		0 to + 50	°C
Relative humidity range (<i>operating</i>)		20 to 85 <i>no condensing</i>	%
Operating voltage range Vch (<i>dot</i>)		22-26 / 10,5-14	V DC
Peak print head current (<i>all dots "on" at nominal value</i>)		8.8	A
Current consumption: stepping motor for paper feed		420	mA
Current consumption: stepping motor for cutter		300	mA
Electrical life time*		10 ⁸	pulses
Mechanical life time*		50	Km
Cutter life time		1 000 000 cuts (with paper reference 2320061)	-
Over all dimensions: (<i>without paper roll</i>)	Height	112	mm
	Width	124.5	mm
	Depth	168	mm
Weight (<i>average</i>) (<i>without paper roll</i>)		1500	g

* Per AXIOHM standard test conditions (which are mainly: 24V, 25 °C, dot printing duty cycle = 30 %)

2. MECHANICAL SPECIFICATIONS

2.1. Overall dimensions – Paper exit position

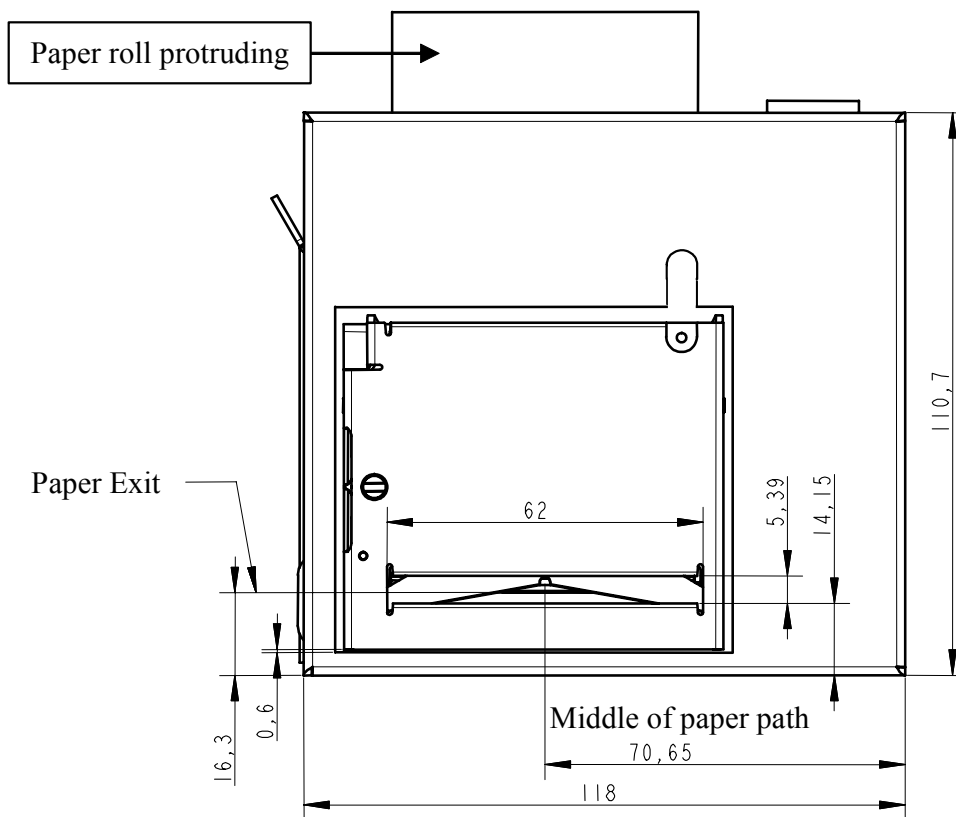
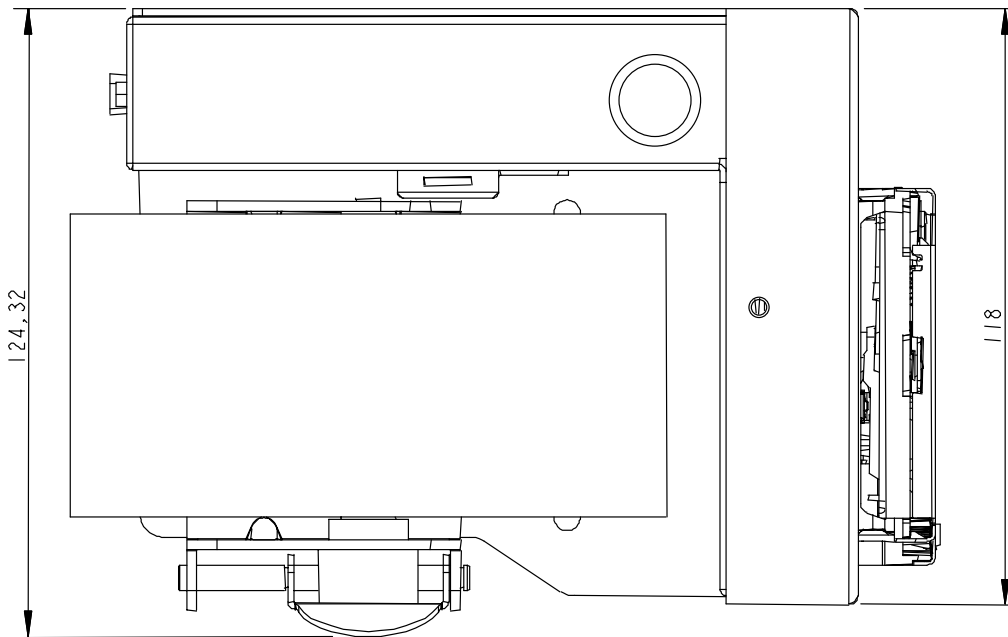

2.2. Fixing Points Position

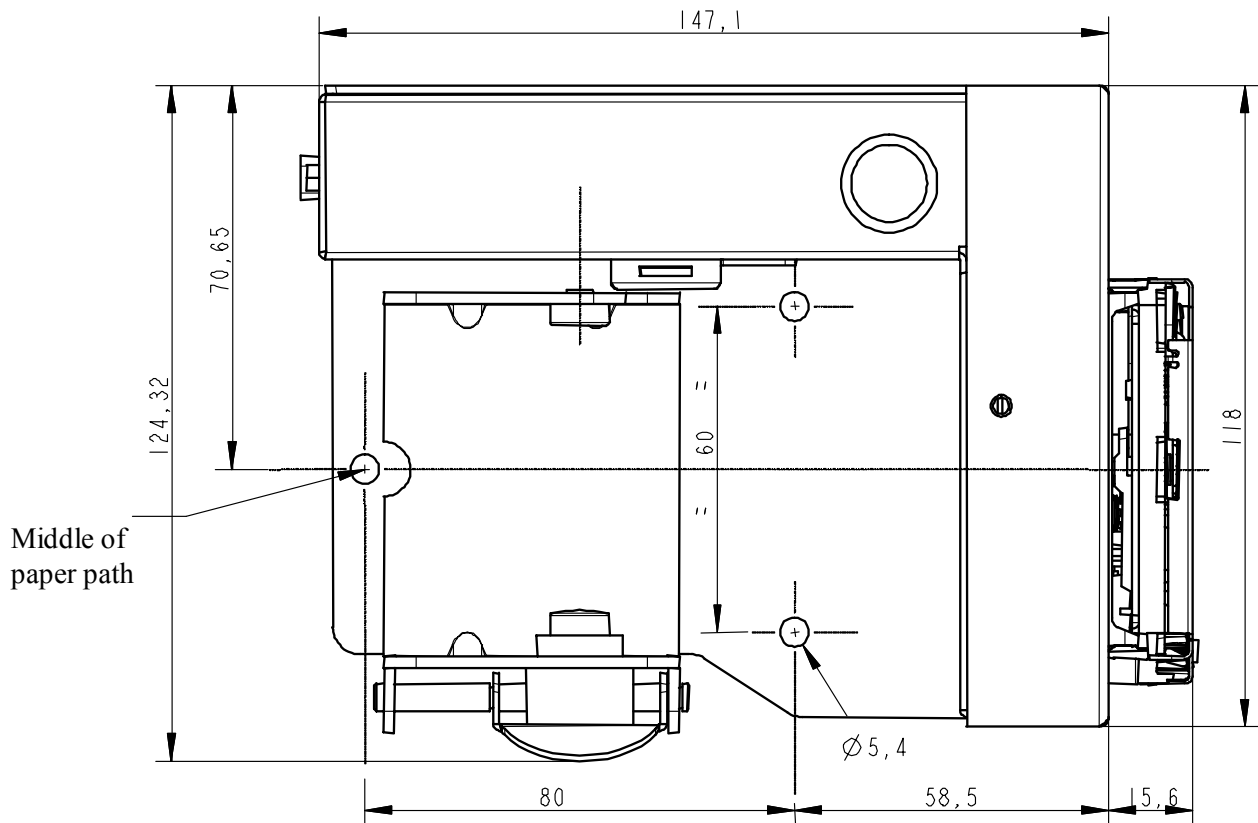

2.3. Notes:

- The paper roll can be up to 120 mm diameter (3.72 inches); in this case it protrudes at the top and the rear of the overall dimensions of the printer without paper roll.
- The roll holder system involves a lever and a spring; in your integration design make sure the access to the lever is convenient and the lever movement is free (see drawings below).

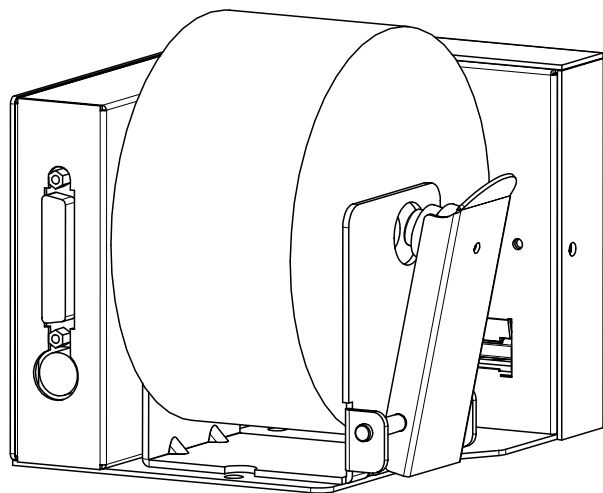
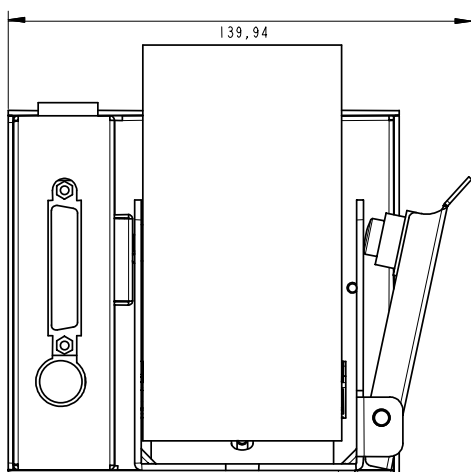

Dimensions with a 120 mm paper roll

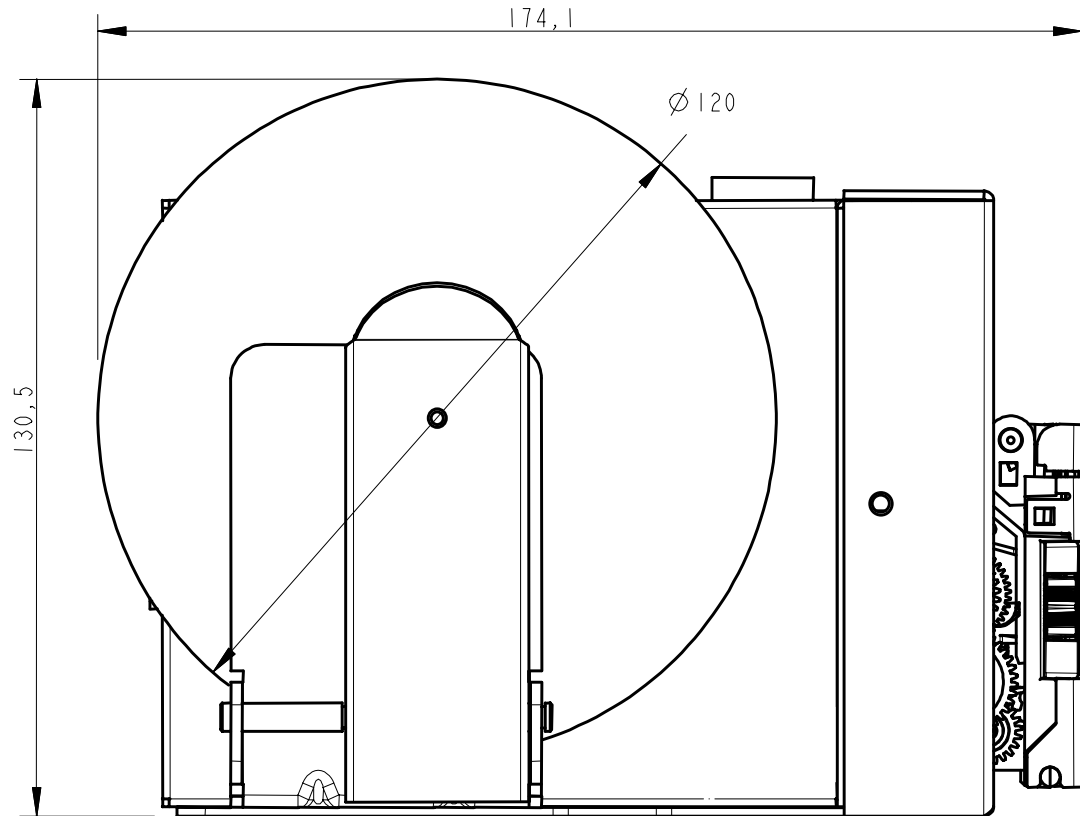

3. RECOMMANDATIONS

3.1. General Mechanical Integration:

- Leave enough room to activate the axel lever to load paper.
- The paper is self loaded when presented in the paper entry slot (if the printer is powered). Depending on the access left to load the paper, a label can help the final user to understand how to load the paper end and paper roll. The paper end should be inserted prior to set the roll on the hinged axle.
- Opening the cover that contains the cutter is just an option for un-jamming and for easy cutter replacement. It is not necessary to open it for standard loading. Opening and closing it without manually setting the paper trough the blades will lead to a jam.

3.2. Paper exit protection:

The main factor that can create a paper jam with those mechanisms is a receipt that is stuck at the paper exit. This can be done either by a user that holds the receipt, or if there is some static electricity in the chute, or if the paper chute curve is not smooth enough giving to much friction on the receipt for a correct feeding (this last point is amplified in high humidity conditions).

Depending on your application & the receipt length you may have to consider protecting the receipt so that it cannot be grabbed or stopped while it is printed. This can be done with a chute or a drop box.

The chute curve has to be smooth enough; it is important though to spend some time to prototype and test your design in different environmental conditions.

The drop box can be a good option – it is important in that case to make sure static electricity will not get the receipt stuck before it drops in the box. It was necessary for some application to add a conductive brush that touched the paper at the exit and was connected to the walls of the drop box.

3.3. Grounding:

The printer chassis should be grounded – this can easily be done via the fixing points.

3.4. Power supply:

The power supply must be 24V DC, 55 Watts minimum.

Even though the mean current stays reasonable (around 2A when printing depending on how loaded the receipt is); the power supply must handle higher currents peaks on short amounts of time.

3.5. Paper setting:

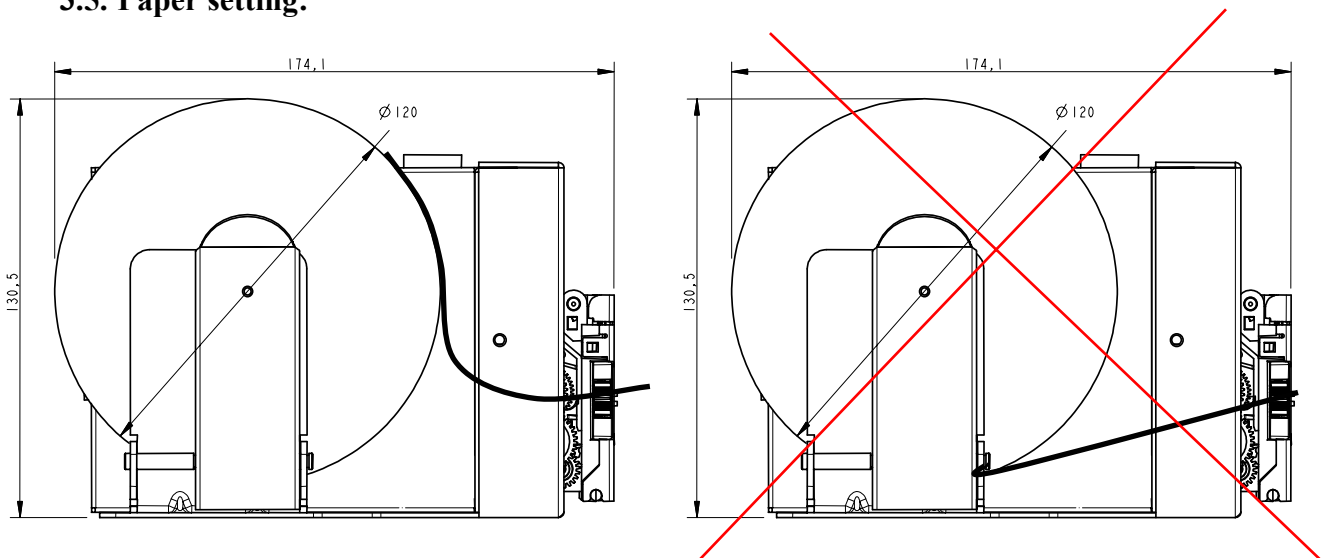

4. BOARD CONNECTION

4.1. Power Supply Connector (female)

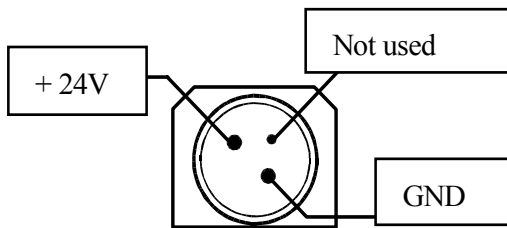

Printer/PCB side

For power supply end use a male 3 pin connector Mini Din.

It is possible and recommended to use some with self blocking feature.

Possible supplier: Hosiden

4.2. Data Connector Description

DB25 Connector

Pins	1 : STROBE	8 : D6	15 : FAULT	22 : GND
	2 : D0/ <i>TXD</i>	9 : D7	16 : INIT	23 : GND
	3 : D1/ <i>RXD</i>	10 : ACK	17 : SELECT IN	24 : GND
	4 : D2/ <i>RTS</i>	11 : BUSY	18 : GND	25 : GND
	5 : D3/ <i>CTS</i>	12 : ERROR	19 : GND	
	6 : D4/ <i>DSR</i>	13 : XFLAG	20 : GND/ <i>DTR</i>	
	7 : D5/ <i>GND</i>	14 : AUTOFD	21 : GND	

Bold and italic pins are for RS232 communication. The others are for IEEE 1284 communication.

5. PROTOCOL COMMUNICATION

5.1. Communication Port Parameters

Default RS232 parameters:

(can be set by the user) **Baud rate** : 115200
 Parity bit : None
 Data bits : 8
 Stop bits : 1

5.2. IEEE 1284 communication

The interface is always initialized to the Compatibility Mode, a conventional, unidirectional host-to-peripheral interface. From the Compatibility Mode, the host may transmit data to the peripheral using the Compatibility Mode or direct the interface into an another mode.

In our case, the communication mode used is the NIBBLE MODE, an asynchronous, reverse (peripheral-to-host) channel, under control of the host. Data bytes are transmitted as two sequential 4-bit nibbles, using four peripheral-to-host status lines. This communication mode consists of more phases:

- **reverse data transfer phase:** When data transfers from the peripheral to the host.
- **reverse host busy data available phase :** When the peripheral has data to transmit
- **reverse host busy data not available phase:** When the peripheral has no more data to transmit.
- **reverse idle phase:** When no data transfer is in progress and the host is waiting for peripheral data. When data are available, the peripheral will cause the interface to go to the reverse interrupt phase.
- **reverse interrupt phase:** A phase that provides the mechanism for the peripheral to alert the host that it has data to transfer. While in this phase, the host may cause the interface to go to the termination phase.

Compatibility Mode signal name	Nibble Mode signal name	Description
nSelectIN	1284 Active	<u>Compatibility mode:</u> Set low by host to select peripheral. <u>Negotiation phase:</u> Set high in conjunction with Host Busy set low to request an IEEE1284 mode. <u>Reverse data transfer phase / Reverse idle phase:</u> Set high to indicate that the bus direction is peripheral-to-host. Set low to terminate IEEE 1284 mode and to set bus direction to host-to-peripheral.
PError	AckDataReq	<u>Compatibility mode:</u> Driven high to indicate that the peripheral has encountered an error in its paper path. The meaning of this signal varies from peripheral to peripheral. Peripherals shall set nFault low whenever PError is set high. <u>Negotiation phase:</u> Set high to indicate IEEE 1284 support, then follows nFault (nDataAvail). <u>Reverse data transfer phase :</u> Data bit 2 then 6 <u>Reverse idle phase:</u> Set high until the host requests a data transfer, then follows nFault (nDataAvail).
Data (8->1)	AD 8->1	<u>Compatibility mode:</u> Forward channel data. <u>Negotiation phase:</u> Extensibility request value.

nAck	PtrClk	<p><u>Compatibility mode</u>: Pulsed low by the peripheral to acknowledge transfer of a data byte from the host.</p> <p><u>Negotiation phase</u>: Set low to acknowledge IEEE 1284 support, then set high to indicate that the Select (Xflag) and data available flags may be read.</p> <p><u>Reverse data transfer phase</u> : Used to qualify data being to the host</p> <p><u>Reverse idle phase</u>: Set low then high by the peripheral to cause an interrupt indicating to the host that data is available.</p>
Busy	PtrBusy	<p><u>Compatibility mode</u>: Driven high to indicate that the peripheral is not ready to receive data.</p> <p><u>Negotiation phase</u>: Reflects the present state of the forward channel of the peripheral.</p> <p><u>Reverse data transfer mode</u>: Data bit 3 then 7, then forward channel busy channel.</p> <p><u>Reverse idle phase</u>: Forward channel busy status.</p>
Select	Xflag	<p><u>Compatibility mode</u>: Set high to indicate that the peripheral is online.</p> <p><u>Negotiation phase / Reverse idle phase</u>: Used by the peripheral to reply to the requested extensibility byte sent by the host during the negotiation phase.</p> <p><u>Reverse data transfer phase</u>: Data bit 1 then 5.</p>
nAutoFeed	Host Busy	<p><u>Compatibility mode</u>: Set low by host to put some printers into auto-line feed mode. May also be used as a ninth, parity, or command / data control bit.</p> <p><u>Negotiation phase</u>: Set low in conjunction with nSelectIN (1284 Active) being set high to request an IEEE 1284 mode. Then set high after the peripheral sets nAck (PtrClk) low.</p> <p><u>Reverse data transfer mode</u>: Set low to indicate that host can receive peripheral-to-host data, then set high to acknowledge receipt of that nibble. Following a reverse channel transfer, the interface transitions to idle phase when nAutoFeed (Host Busy) is set low and the peripheral has no data available.</p> <p><u>Reverse idle phase</u>: Set high in response to nAck (PtrClk) low pulse to re-enter reverse data transfer phase. If set high with nSelectIN (1284 Active) set low, the IEEE 1284 idle phase is aborted, and the interface returns to Compatibility Mode.</p>
nFault	nDataAvail	<p><u>Compatibility mode</u>: Set low by the peripheral to indicate that an error has occurred. The meaning of this signal varies from peripheral to peripheral.</p> <p><u>Negotiation phase</u>: Set high to acknowledge IEEE 1284 compatibility. Then set low to indicate peripheral-to-host data is available following the host setting nAutoFeed (Host Busy) high.</p> <p><u>Reverse data transfer phase</u>: Set low to indicate that the peripheral has the data ready to send to the host. Then used to send data bit 0 (LSB) then 4.</p> <p><u>Reverse idle phase</u>: Used to indicate that data is available.</p>

5.2.1. Compatibility Mode

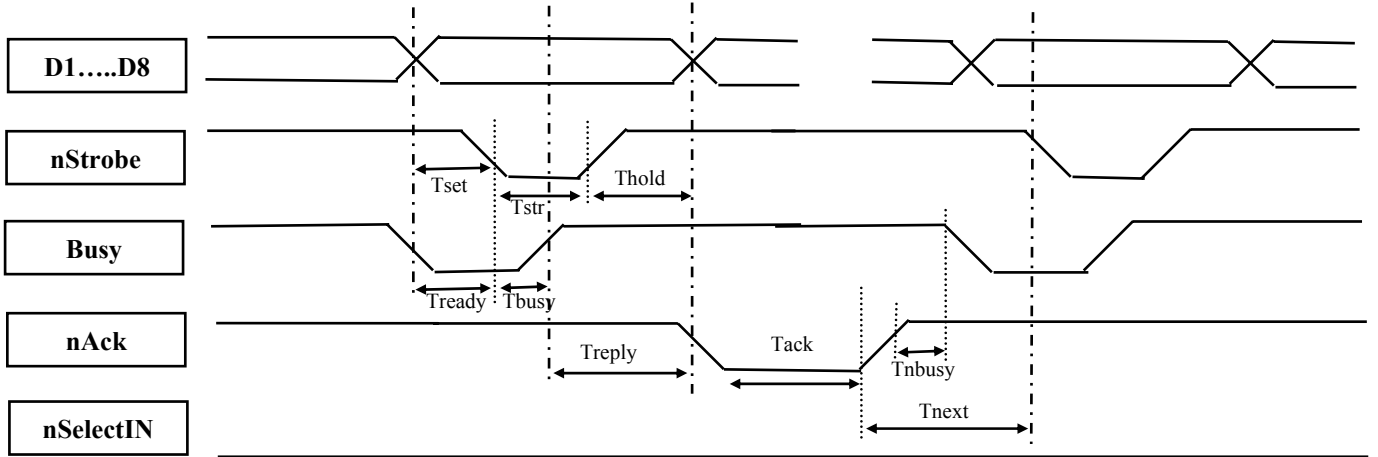

5.2.2. Nibble Mode Negotiation and Transfer

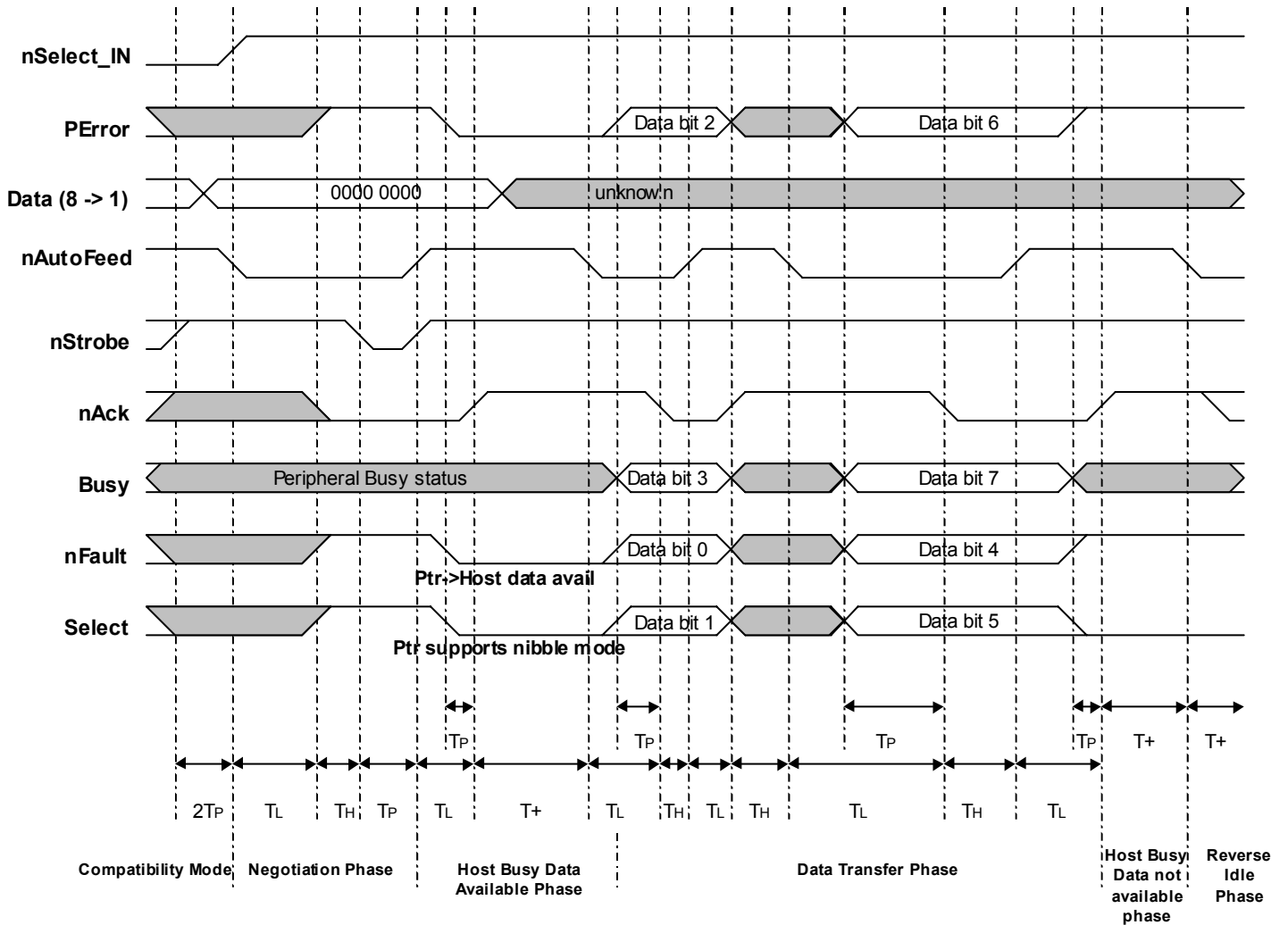

5.2.3. Timing

Time	Min	Max	Description
Tset	/	500 ns	Peripheral
	750 ns	/	Host
Tstr	/	500 ns	Peripheral
	750ns	500 s	Host
Thold	/	500 ns	Peripheral
	750 ns	/	Host
Tready	0	/	/
Tbusy	/	500 ns	/
Treply	0	/	/
Tack	500 ns	10 μ s	/
Tnbusy	0	/	/
Tnext	0	/	/
T _H	0	1,0 s	Host response time
T ₊	0	Infinite	Infinite response time
T _L	0	35 ms	Peripheral response time
T _P	0,5 μ s	/	Minimum setup or pulse width

5.3. RS 232 communication

The RS-232C interface uses either XON/XOFF (software) or DTR/DSR (hardware) protocol to control the flow of information between the computer and the printer.

- In XON/XOFF mode, a particular character is sent back and forth between the host and the printer to regulate the communication.
- In DTR/DSR mode, changes in the DTR/DSR signal on the RS-232C interface controls the information flow.

5.3.1. XON/XOFF Protocol

The XON/XOFF characters control the information transfer between the printer and the host computer. The printer sends an XON character when it is ready to receive data and it sends an XOFF character when it cannot accept any more data. The software on the host computer must monitor the communication link as shown in the following flowchart in order to send data at the appropriate time.

If XON/XOFF has been selected, the printer also toggles the DTR signal, as described in the next section, but it does not look at the DSR signal to transmit data.

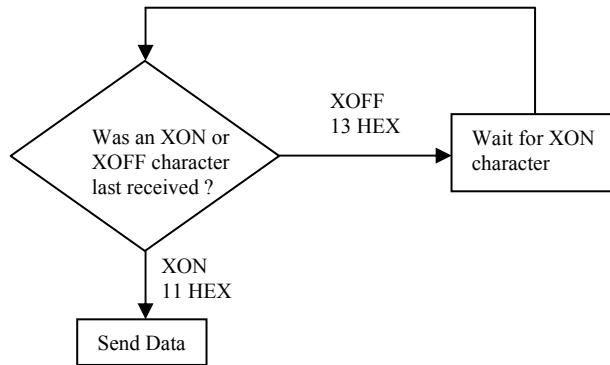

XON character = 0x11 hex.
XOFF character = 0x13 hex.

5.3.2. DTR/DSR Protocol

The DTR signal is used to control data transmission to the printer. It is driven high when the printer is ready to receive data and driven low when it cannot accept any more data. Data is transmitted from the printer after it confirms that the DSR signal is high.

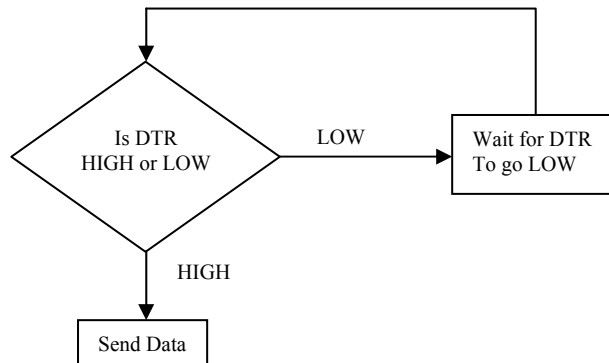

6. GENERAL PCB SPECIFICATIONS

Item	Specification	
Available character types	CP437, User defined characters and Kanji characters	
Bar-code types	Interleaved 2 of 5, UPC- A/B, EAN 8/13, code39, and PDF-417.	
Character configuration	16x24 dot font (Font A) <i>default</i> 9x24 dot font (Font B)	
Maximum Number of Printable Characters per Line	24 characters (16x24 dot font, character spacing 4 dots) <i>default</i> 42 characters (9x24 dot font, character spacing 2 dots)	
Character size	1.5 x 2mm (Font A) <i>default</i> 0.875 x 2 mm (Font B)	
Character spacing	4 dots (16x24 font) <i>default</i> 2 dots (9x24 font)	
Line spacing	3 dots spacing between 2 matrix characters(<i>default value</i>)	
Input buffer	4096 bytes	
Maximum printing speed	80 mm / s Depending on using conditions (voltage, temperature ...)	
Operation Voltage Range	12 V or 24 V depending on the print-head mechanism	
Stand by current	12 Volts min : 10,5 V max : 14 V 130mA (at 12V)	24 Volts min : 22 V max : 26 V 87mA (at 24V)

7. LIST OF CONTROL CODES

Print Commands: (Page 21)

Hex Command	Description
0A	Print & line feed
0C	Form feed
0D	Print and carriage return
14 <i>n</i>	Feed N print lines
15 <i>n</i>	Feed N dot lines
1B 4A <i>n</i>	Print and feed N/2 dots
1B 64 <i>n</i>	Print and feed N lines

Line Spacing: (page 23)

Hex Command	Description
16 <i>n</i>	Set line spacing
1B 32	Set line spacing to 1/6-inch (<i>default</i>)
1B 33 <i>n</i>	Set line spacing

Print position: (Page 18)

Hex Command	Description
09	Horizontal tab
1B 14 <i>n</i>	Set column
1B 24 <i>n1 n2</i>	Set absolute print position
1B 44 <i>n k</i>	Set horizontal tabs
1B 5C <i>n1 n2</i>	Set relative print position
1B 61 <i>n</i>	Select justification
1D 4C <i>nL nH</i>	Set left margin
1D 50 <i>x y</i>	Set horizontal and vertical motion units
1D 57 <i>nL nH</i>	Set printing area width

Character control: (Page 27)

Hex Command	Description
12	Select double-wide characters
13	Select single-wide characters
1B 12	Rotate characters counter-clockwise
1B 20 <i>n</i>	Set right-side char spacing
1B 21 <i>n</i>	Select printing modes
1B 25 <i>n</i>	Select/Cancel user-defined char set
1B 26 <i>s c1 c2 n1 dl..nn</i>	Define user-defined character
1B 2D <i>n</i>	Turn underline mode on/off
1B 3F <i>n</i>	Cancel user-defined char
1B 45 <i>n</i>	Bold Print mode on/off
1B 47 <i>n</i>	Double strike mode on/off
1B 49 <i>n</i>	Italic Print mode on/off
1B 56 <i>n</i>	Turn 90 degrees clockwise mode on/off
1B 7B <i>n</i>	Upside down printing mode on/off
1D 42 <i>n</i>	White/Black reverse print mode

Bit image: (Page 35)

Hex Command	Description
11 <i>n1... nl</i>	Graphic printing mode
1B <BMP file>	Download BMP file
1D 2A <i>n1 n2 d1.....dn</i>	Define download bit image
1D 2F <i>m</i>	Print download bit image

Bar Code: (Page 37)

Hex Command	Description
1D 48 <i>n</i>	Select printing position for HRI char
1D 66 <i>n</i>	Select font for HRI char
1D 68 <i>n</i>	Select barcode height
1D 6B <i>k</i> <data> 0	Print bar code
1D 77 <i>n</i>	Set bar code width

Status: (Page 40)

Hex Command	Description
1B 76	Transmit paper sensor status
1D 61 <i>n</i>	Enable / Disable Auto Status Back (ASB)

Mechanism control: (Page 41)

Hex Command	Description
1B 69	Execute full cut
1B 6D	Execute partial cut

Flash Download: (Page 42)

Hex Command	Description
1B 5B 7D	Switch to Flash Download mode
1D 00	Request Printer Identification
1D 01	Request Flash Memory Size
1D 02 <i>n</i>	Select Flash Memory Sector to Download
1D 06	Check Flash CRC
1D 07	Return Boot Sector CRC
1D 0E	Erase all Flash contents except Boot Sector
1D 0F	Return main Program Flash CRC
1D 10 <i>n</i>	Erase Selected Flash Sector
1D 11 <i>a1 ah cl ch d1... d</i> (<i>ch*256 +cl</i>)	Download to Active Flash Sector
1D FF	Firmware Reset

Other commands: (Page 46)

Hex Command	Description
10	Clear printer buffer
1B 40	Initialise printer
1D 22 <i>n</i>	Select memory type (SRAM / FLASH) where to save logos or user's defined fonts
1D 22 55 <i>n1 n2</i>	Flash Memory User Sector Allocation
1D 40 <i>n</i>	Erase User Flash Sector
1D 73 01 <i>n</i>	Threshold Setting (for end of paper sensor)
1D 73 06 <i>n</i>	Paper Low Threshold
1F 02 <i>n1.....n6</i>	RS232 configuration
1F 03 9C <i>n</i>	End of Paper Sensor Management
1F 0A <i>n</i>	Voltage and Temperature Monitoring
1F 74	AUTOTEST

Feed N dot lines

ASCII NAK *n*

Hex 15 *n*

Comments This command allows the user to feed *n* dot lines (*n* / 8mm; *n* / 203 inches) before printing another line.
 $00 \leq n \leq 7F$

Print and feed N/2 dots

ASCII ESC j *n*

Hex 1B 4A *n*

Comments Prints one line from the buffer and feeds the paper with *n*/203 inch step (*n*/8 mm).

Print and feed N lines

ASCII ESC d *n*

Hex 1B 64 *n*

Comments This command prints the data contained in the buffer and performs *n* linefeeds so that printing will start at the beginning of the line below.

n	Function
$00 \leq n \leq FF$	<i>n</i> linefeeds

8.2. Line Spacing

Set line spacing

ASCII SYN *n*
Hex 16 *n*

Comments This command allows the user to define line spacing as character height plus $n/203$.
 $00 \leq n \leq 0C$

Set to default line spacing

ASCII ESC 2
Hex 1B 32

Comments This command sets the line spacing to 1/6 inch (4, 23 mm).

Set line spacing N dots

ASCII ESC 3 *n*
Hex 1B 33 *n*

Comments This command sets the line spacing to $n/360$ of an inch. Minimum line spacing is 7.5 lines per inch. The line equals the character height when *n* is too small.

8.3. Print position

Set horizontal tab

ASCII ESC D *n k NUL*

Hex 1B 44 *n k*

Comments <n> is the number of characters that the horizontal tab will jump.
Enable only for one line.
01h ≤ n ≤ 19h
<k> = 00

Horizontal tab

ASCII HT

Hex 09

Comments This command moves the printing position to the next horizontal tab position.
The horizontal tab position is defined by "Set horizontal tab" function.
Default tabs are every 8 characters.

Ex : 09 41 41 41 41 41 41 41 41 41 0A

⇒ _____AAAAAAAA

Set column

ASCII ESC DC4 *n*

Hex 1B 14 *n*

Comments This command allows the user to start the next line in character column *n*.
Standard mode: 01h ≤ n ≤ 18h

Set relative print position

ASCII ESC \ *n1 n2*

Hex 1B 5C *n1 n2*

Comments This command sets the print starting position to the specified number of dots (1/8 mm units) **from the current printing position, where position = current position + (n1 + n2 x 256)**. If the position exceeds the print area, the command is ignored.

n2	n1
00	00 - FF
01	00 - 80 for a printing area of 48mm (384 dots)

Set absolute print position

ASCII ESC \$ *n1 n2*

Hex 1B 24 *n1 n2*

Comments This command sets the print starting position to the specified number of dots (1/8 mm units) **from the beginning of the line so that the position is (n1 + n2 x 256) dots from the left hand side.** If the position exceeds the printing area, the command is ignored.

n2	n1
00	00 - FF
01	00 - 80 for a printing area of 48mm (384 dots)

Select justification

ASCII ESC a n

Hex 1B 61 n

Comments This command should be at the start of a new line, and is otherwise ignored.

n	Function
00	Align left (default)
01	Align centred
02	Align right

1B 61 n =>

Ex:

n = 00

ABC

ABCD

ABCDE

n = 01

ABC

ABCD

ABCDE

n = 02

ABC

ABCD

ABCDE

Set horizontal / vertical motion unit

ASCII GS P x y

Hex 1D 50 x y

Comments This command allows the user to define the vertical and horizontal motion units to 1/x and 1/y inch. Used with "Set line spacing", "Print and feed paper" and "Set absolute/relative print position" functions.

default value: x = 203 and y = 203

Range: 00h < x < FFh

00h < y < FFh

Set print area width

ASCII GS W nL nH

Hex 1D 57 nL nH

Comments This command allows the user to define the print area width. The maximum right position is nL+256*nH.

Set left margin

ASCII GS L nL nH

Hex 1D 4C nL nH

Comments This command allows the user to the left margin in standard mode. The new margin is : nL + 256*nH. No action if not at the beginning of a new line and doesn't affect page mode printing.

KRM kiosk printer	User's manual page 26 / 52	Ref. : 31 08 212	Issue : Z
-------------------	----------------------------	------------------	-----------

8.4. Character control

Select single-wide characters

ASCII DC3
Hex 13

Comments This command allows to return to single wide mode when the double wide mode has been selected.

Ex : 12 41 41 41 41 **13** 41 41 41 41
 ⇒ **AAAA** ⇒ AAAA

Select double-wide characters

ASCII DC2
Hex 12

Comments This command doubles the size of characters. The printer is reset to single-wide mode after a line has been printed or the Clear Printer (10) command is received. Double-wide characters may be used in the same line with single-wide characters.

Ex : 41 41 41 41 **12** 41 41 41 41
 ⇒ AAAA ⇒ **AAAA**

Rotated characters counter-clockwise

ASCII ESC DC2
Hex 1B 12

Comments This command rotates characters counter-clockwise. To cancel this mode, just send the clear printer buffer command : DLE (10H)

Ex : **1B 12** 41 41 41 41 41
 ⇒ **Λ Λ Λ Λ Λ**

Set right-side char spacing

ASCII ESC SP *n*

Hex 1B 20 *n*

Comments This command sets spacing to right of characters in dots. In double width mode, the amount of space is doubled also.
 $00h \leq n \leq 20h$

Select printing mode

ASCII ESC ! *n*

Hex 1B 21 *n*

Comments *n* is an 8 bits word converted in hexadecimal. It can be set to vary the printing mode according to the table below. Default value is *n*=0 (i.e. Font A in standard mode)

Bit	Function	Bit =0	Bit =1
0	Character Font	A	B
1	(not used)	-	-
2	(not used)	-	-
3	Emphasised	Cancelled	Set
4	Double height	Cancelled	Set
5	Double width	Cancelled	Set
6	(not used)	-	-
7	Underlined	Cancelled	Set

Turn underline mode on/off

ASCII ESC - *n*

Hex 1B 2D *n*

Comments This command allows or not the underline mode and defines the thick of the line under the text.

N	Function
00	Cancel underline print (default)
01	Begin underline 1 dot thick
02	Begin underline 2 dots thick

Ex : **1B 2D 00** 41 41 41 **1B 2D 01** 41 41 41 **1B 2D 02** 41 41 41

⇒AAA

⇒ AAA

⇒ AAA

Bold print mode on/off

ASCII ESC E *n*

Hex 1B 45 *n*

Comments This command has the same effect as printing twice the character at the same printing position.

n	Function
00	Cancel bold print (default)
01	Begin bold print

Ex : **1B 45 00** 41 41 41 **1B 45 01** 41 41 41
 ⇒ AAA ⇒ AAA

Double strike mode on/off

ASCII ESC G *n*

Hex 1B 47 *n*

Comments This command has the same effect as bold printing the character.

n	Function
00	Cancel bold print (default)
01	Begin bold print

Ex : **1B 47 00** 41 41 41 **1B 47 01** 41 41 41
 ⇒ AAA ⇒ **AAA**

Italic print mode on/off

ASCII ESC I *n*

Hex 1B 49 *n*

Comments When this command is set "on", the top third of each character is printed two dots to the right, the middle third is printed one dot to the right, and the bottom third is printed at the same position as standard characters.

n	Function
0	Cancel italic print (default)
1	Begin italic print

Ex : **1B 49 00** 41 41 41 **1B 49 01** 41 41 41
 ⇒ AAA ⇒ *AAA*

Turn 90° clockwise mode on/off

ASCII ESC V *n*

Hex 1B 56 *n*

Comments This command causes each character or bar code to be rotated 90° clockwise.

n	Function
0	Cancel rotated print
1	Set rotated print

Ex : 1B 56 00 41 41 41 1B 56 01 41 41 41

⇒ AAA ⇒ ↵↵↵

Upside down printing mode on/off

ASCII ESC { *n*

Hex 1B 7B *n*

Comments This command rotates the printed characters by 180°. The command is valid only when it is used at the beginning of the line.

n	Function
00	Cancel rotated characters (default)
01	Begin rotated characters

Ex : 1B 7B 00 41 41 41 1B 7B 01 41 41 41

⇒ AAA ⇒ √√√

White/Black reverse print mode

ASCII GS B *n*

Hex 1D 42 *n*

Comments This command causes each character to be printed with reversed background and foreground (white characters on black background).

n	Function
00	Cancel inverse characters
01	Set inverse characters

Ex : 1D 42 00 41 41 41 1D 42 01 41 41 41

⇒ AAA ⇒ **AAA**

Define user-defined character

ASCII ESC & *s n m a [p1 p2 ... p(s * a)] (m-n+1)*

Hex 1B 26 *s n m a [p1 p2 ... p(s x a)] (m-n+1)*

Comments " *s* " specifies the number of bytes in the vertical direction.
 " *n* " specifies the beginning ASCII code for the definition and " *m* " the final code. If only one character is defined, use $n = m$.
 The allowable character code range is from ASCII code <20 h> to <7E h> and the maximum number of character is 95.
 " *a* " specifies the number of dots in the horizontal direction.
 " *p* " is the dot data for the characters. The dot pattern for a dot is in the horizontal direction from the left side (the remaining dot pattern on the right side is space, the amount of data to be defined is $s * a$).
 After user defined characters are defined once, they are available until an other definition is made, ESC @ is executed, GS * is executed or the printer is turned off.

If $a \leq A$ character horizontal size is A (A : horizontal size of selected font).

If $a > A$ character horizontal is a.

Byte	Description
<i>s</i>	Height in octets ($s=03$ h for 24 bits)
<i>n</i>	20 h $\leq n \leq m \leq 7E$
<i>m</i>	Starting and final code
<i>a</i>	$0 \leq a \leq 10$ h
<i>p1 ... p(s x a)</i>	00 h $\leq p1...p_{s \times a} \leq FF$ h

See example next page

Font A is selected :

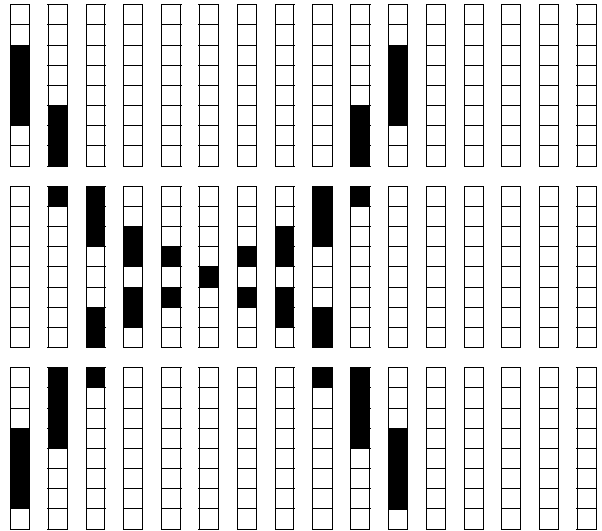
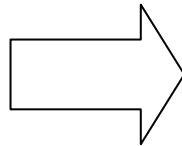
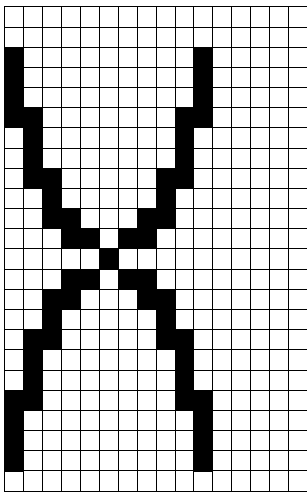
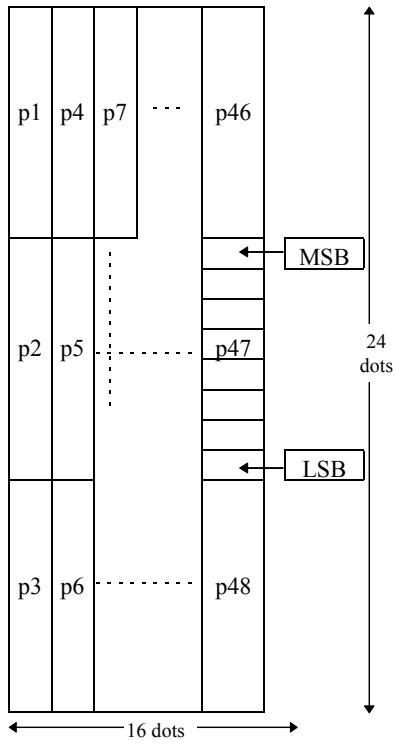

p1 = <3C>H	p4 = <07>H	p7 = <00>H....
p2 = <00>H	p5 = <80>H	p8 = <E3>H....
p3 = <1E>H	p6 = <F0>H	p9 = <80>H....

Font B is selected :

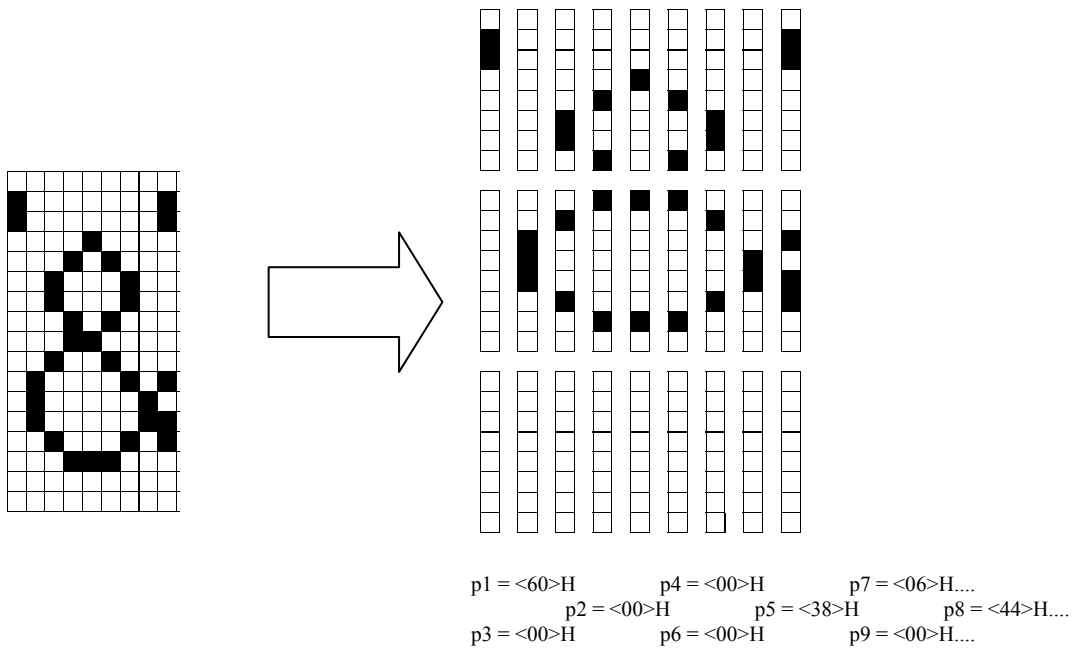
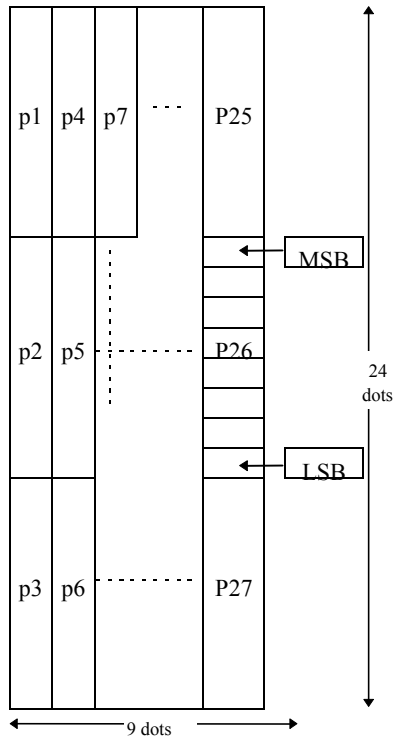

Select/Cancel user-defined char set

ASCII ESC % *n*

Hex 1B 25 *n*

Comments This command allows to choose between two fonts, the resident font and the user defined font.
The user defined character set and a down-loaded bit image can not be defined at the same time.

n (00-FF)	Function
Even	Select resident fonts
Odd	Select user-defined font

Cancel user-defined char

ASCII ESC ? *n*

Hex 1B 3F *n*

Comments This command cancels the user-defined characters defined for the character code *n*. After the user-defined characters is cancelled; the internal character set is printed.

8.5. Bit image

Graphic printing mode

ASCII DC1 $n1, n2, \dots, n48$ (where n_i represents 8 dots).

Hex 11 $n1, n2, \dots, n48$ (where n_i represents 8 dots).

1	0	1	1	0	0	1	1
Black	White	Black	Black	White	White	Black	Black

MSB **LSB**

Comments This command specifies a single line of graphic data for 384 dots, the print zone for the printer. The data is sent as 48 bytes, or 384 bits, representing the dots to be “on” or “off”.

Example : 11 0F 4C

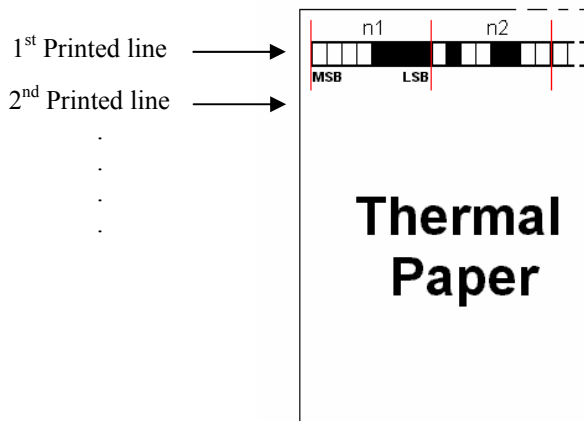

Download BMP logo

ASCII ESC < BMP file >

Hex 1B < BMP file >

Comments To download a BMP file saved as a logo, send 1Bh character followed by the whole BMP file. The download BMP logo can be printed by using the Print Download Image command (1D 2F n). **BMP file images that are not monochrome are ignored.**

Define download bit image

ASCII GS * n1 n2 d ... d(n1 x n2)
Hex 1D 2A n1 n2 d ... d(n1 x n2)

Comments User-defined graphics are stored in volatile memory. Each graphic is stored in a “cell” which is individually addressable and may be up to 384 dots wide x 255 dots high in size (maximum 128 KB total). Each graphic cell may vary in size. The graphic cell remains available until another GS * definition to the same cell is made, ESC @ is executed, or the printer is reset/turned off. If the command would result in exceeding available memory, it is ignored.

Byte	Description
n1	Width ÷ 8 dots (1 to 48)
n2	Height ÷ 8 dots (1 to 255)
d1 ... d(n1 x n2)	n1 x n2 bytes of character data. 1 bit per dot, top to bottom then left to right.

Example :

Here is an example of a bit image ; n1 = 02, n2 = 02 and Data are given below : (see next page)

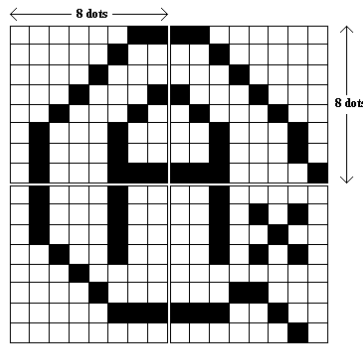

Data : 00 00 07 E0 08 10 10 08 20 04 47 F2 89 02 91 02 91 02 89 02 47 F2 20 04 10 54 08 22 06 51 01 00

To print the download bit image use the next command.

Print download bit image

ASCII GS / m
Hex 1D 2F m

Comments Prints the current graphics cell defined by the GS * command.

m	Function
0	Print normal
1	Print double width
2	Print double height
3	Print double width and height

8.6. Bar code

Select printing position for HRI char

ASCII GS H *n*

Hex 1D 48 *n*

Comments This command allows the user to select the position for the barcode numbers.

n	Description
00	Numbers are not printed
01	Numbers are printed at the top of the barcode
02	Numbers are printed at the bottom of the barcode
03	Numbers are both printed at the top and the bottom

Select font for HRI char

ASCII GS f *n*

Hex 1D 66 *n*

Comments This command allows the user to select font of the HRI characters. **Only used for barcode.**
If n=00 Standard font
If n=01 Compressed font.

Select barcode height

ASCII GS h *n*

Hex 1D 68 *n*

Comments This command allows the user to define the barcode height.
00 < n < FF

Select barcode width

ASCII GS w *n*

Hex 1D 77 *n*

Comments This command allows the user to define the barcode width. **Note that if the barcode is too longer, no printing.** $1 \leq n \leq 5$ **default value : n = 2**

Print barcode

ASCII GS k k <data> NUL

Hex 1D 6B k <data> NUL

Comments This command allows the user to print barcode.

k	
00	Code UPC-A mode 1
01	Code UPC-E mode 1
02	Code EAN-13 mode 1
03	Code EAN-8 mode 1
04	Code 39 mode 1
05	Interleaved 2 of 5
41	Code UPC-A mode 2
42	Code UPC-E mode 2
43	Code EAN-13 mode 2
44	Code EAN-8 mode 2
45	Code 39 mode 2
0A	PDF 417

There are two variations to this command.

The first variation uses a "NUL" character to terminate the string (**mode 1**).

The second variation the length of byte is specified at the beginning of the string (**mode 2**).

For the Code39 barcode, beginning and finishing characters are necessary : 2A 2A

Note that if the barcode is too longer, no printing.

Description of the Interleaved 2/5 bar code :

Here is the table describing the bit representation of numbers 0 to 9.

Number	Bit representation				
0	0	0	1	1	0
1	1	0	0	0	1
2	0	1	0	0	1
3	1	1	0	0	0
4	0	0	1	0	1
5	1	0	1	0	0
6	0	1	1	0	0
7	0	0	0	1	1
8	1	0	0	1	0
9	0	1	0	1	0

bit representation :
"1" represents a large bar.
"0" represents a small bar.

See example next page

Here is the algorithm which is used to make a bar code from numbers :

Example : 1234

- 1 - There must have an even number of digits else a zero is placed at the beginning.
123 is traduced by 0123.
- 2 - The number is divided in two digit pairs described as follows :
1234 -> 12 34
- 3 - Then, digits are encoded by pairs.
1 3 (digits encoded by bars)
2 4 (digits encoded by spaces)

figure :

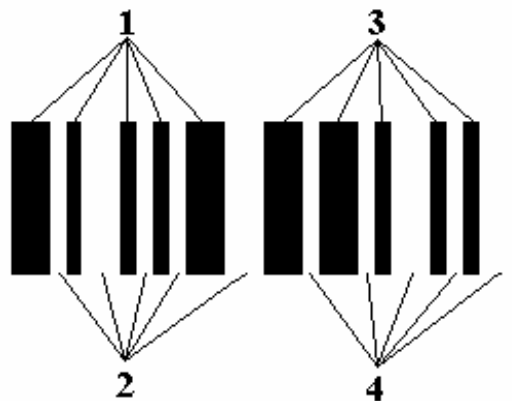

The user number is between two codes : the beginning code and the ending code.

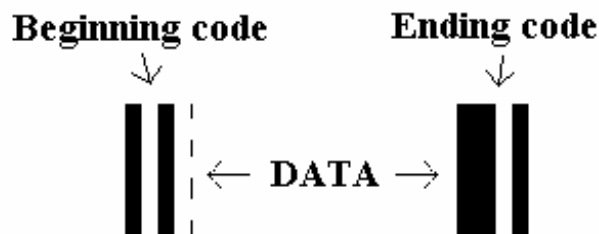

The result is :



8.7. Status

Transmit paper sensor status

ASCII ESC v

Hex 1B 76

Comments This command allows the user to request the status of the printer.
One byte is returned by the board.

Bit	Bit = 0	State	Bit = 1	State
0	Paper Out	OK	Paper Out	NO PAPER
1	Paper Low	OK	Paper Low	LOW PAPER
2	Knife in normal open position	OK	Knife in normal open position	ERROR
3	Conveyer In	OK	Conveyer In	ERROR
4	Conveyer Out	OK	Conveyer Out	ERROR
5	Cover	CLOSE	Cover	OPEN
6	Print-head Temperature	OK	Print-head Temperature	ERROR
7	Power supply	OK	Power supply	ERROR

Enable/Disable Unsolicited Status Mode

ASCII GS a n

Hex 1D 61 n

Comments This command Enable or disable an automatic status return mode
1D 61 01 : If a parameter changes (Cutter, paper ...), a byte is sent back to the computer.
1D 61 00 : If a parameter changes, nothing appears.

8.8. Mechanism control

Execute full cut

ASCII ESC i

Hex 1B 69

Comments This command allows to full cut the paper.

Execute partial cut

ASCII ESC m

Hex 1B 6D

Comments This command allows to partial cut the paper.

8.9. Flash Download

Warning : Use these commands only if you really understand them.
When you receive update version of the firmware, you will also receive a program which will allow you to download it for a PC.

Introduction.

This defines the protocol used to communicate download information to a printer from an application through a communications link, either serial or parallel. Requests are provided to download data to flash memory, to query the state of the firmware, calculate the firmware CRC and other functions.

There are two methods of entering the download mode:

- While the printer is running normally, using a supervisory request to leave normal operation and enter the download mode.
- Download mode is automatically entered if Flash is found corrupted during Level 0 diagnostics performed after Reset.

The printer never goes directly from the download mode to normal, runtime operation. Either the operator must turn power off, then on, to reboot, or the application sends a command to end download mode and reboot.

Switch to Flash Download Mode

ASCII ES []
Hex 1B 5B 7D

This request causes the printer to cease processing requests for the current emulation and causes it to enter download mode. This mode can also be configured as a diagnostic. Normally, this mode is either not exited (the printer is turned off) or the printer is requested to reboot.

Download Mode Requests

These requests control downloading of flash memory. No application printing occurs. The download mode requests are independent of the printer emulation.

If the printer is put into download mode at runtime, the current communications parameters remain effective.

Request Printer Identification

(also available in runtime operation)

ASCII GS NUL
Hex 1D 00

The printer transmits a string containing an identifier. Format and content of identifier is to be determined.
The content should identify the mechanism as well as the firmware currently loaded.

KRM kiosk printer	User's manual page 42 / 52	Ref. : 31 08 212	Issue : Z
-------------------	----------------------------	------------------	-----------

Request Flash Memory Size

(also available in runtime operation)

ASCII GS SOH
Hex 1D 01

This command returns the type of the flash part used. This provides a means of assurance that the firmware to be downloaded is appropriate for the part used. The value returned is actually the maximum sector (64kbytes segment) number that can be accepted by the request to select a sector for download (1D 02 nn).

Ex: 29F200 part contains 256 Kbytes => the printer returns 03.

Select Flash Memory Sector to Download

(available only in Download Mode)

ASCII GS STX n
Hex 1D 02 n

This command permits to select the flash sector (n) for which the next download operation applies. The values of the sector possible are restricted, depending upon the flash part type. The printer transmits an ACK if the sector number is acceptable; it transmits a NAK otherwise. Sector numbers start at 0.

Check Flash CRC

(also available in runtime operation)

ASCII GS ACK
Hex 1D 06

This command causes the printer to check the Flash firmware CRC.
It transmits ACK if the calculated CRC was correct and NAK if the CRC is incorrect.

Return Boot Sector CRC

(also available in runtime operation)

ASCII GS BEL
Hex 1D 07

This command returns the CRC calculated over the Boot sector code space in the following manner:
ACK <low byte> <high byte>

Erase all Flash contents Except Boot Sector

(available only in Download Mode)

ASCII GS SO
Hex 1D 0E

This command causes the entire flash chip to be erased, EXCEPT Boot sector.
It returns ACK if successful, NAK otherwise.

Return main Program Flash CRC

(also available in runtime operation)

ASCII GS SI
Hex 1D 0F

This command returns the CRC calculated over the Flash firmware code space. The format of the response is:
ACK <low byte> <high byte>.

Erase Selected Flash Sector

(available only in Download Mode)

ASCII GS DLE
Hex 1D 10 n

The sector previously selected is erased. If successful, then the printer transmits ACK. If unsuccessful or no sector has been selected, the printer transmits NAK. The parameter specifies whether or not a CRC is added to the end of the erased sector. If the parameter is 0, then the sector has no CRC added; otherwise the CRC for an erased sector is added.

Download to Active Flash Sector

(available only in Download Mode)

ASCII GS DC 1 al ah cl ch d1...dn
Hex 1D 11 al ah cl ch d1 ... d(ch*256 + cl)

Contains a start address(ah*256 + al) and count(ch*256 + cl) of binary bytes to load into the selected sector, followed by that many data bytes. The start address is relative to the start of the sector. Addresses run from 0 to 64K. The printer may return one of several responses. ACK means that the data was written correctly and the host should transmit the next block. NAK means that, for some reason, the data was not written correctly. This could mean that communications failed or that the write to flash failed. The alternatives seem to be to retry the block or halt loading and assume a hardware failure.

Firmware Reset

(also available in runtime operation)

ASCII GS (space)
Hex 1D FF

Ends the load process and reboots the printer. Before executing this command, the printer should have firmware loaded and external switches set to the runtime settings. Application software for downloading should prompt the user to set the external switches and confirm before sending this command. If the downloading was started from a diagnostic, the reboot will cause the printer to enter download state unless the external switches are changed.

Appendix: Control Character definitions.

06h (ACK):

- sent when the printer has received a host transmission and has completed the request successfully.

15h (NAK):

- sent when a request is unsuccessful.

8.10. Other commands

Clear printer buffer

ASCII DLE
Hex 10

Comments This command clears the buffer of the printer.

- Double-Wide command (12) is cancelled
- Line Spacing, Pitch, and User-Defined Character Sets are maintained at current selections (RAM is not affected)
- Single-Wide, Single-High, Non-Rotated, and Left-Aligned characters are set
- Printer is restarted and error status is cleared in a fault condition
- Printing position is set to column one

Select memory type to save logos and user's defined fonts

ASCII GS " *n*
Hex 1D 22 *n*

Comments This command allows the user to select the memory type where to save logos and user-defined fonts.
Default : Logos are saved in Flash
User-defined fonts are saved in RAM

Value of *n* **30h-33h**

***n* = 30h (ASCII *n* = 0)**

Loads active logo to RAM only. This is used to print a special logo but not have it take up flash memory. A logo defined following this command is not preserved over a power cycle.

***n* = 31h (ASCII *n* = 1)**

Loads active logo to flash memory. This is the default condition for logo flash storage. A logo defined following this command is stored in flash memory.

***n* = 32h (ASCII *n* = 2)**

Loads user-defined characters to RAM only. This is the default condition for user-defined character storage. Any user-defined characters defined following this command are not preserved over a power cycle.

***n* = 33h (ASCII *n* = 3)**

Loads user-defined characters to flash memory. An application must use this command to store user-defined characters in flash memory. Any user-defined characters defined following this command are stored in flash memory. A user-defined character cannot be redefined in flash memory. The flash memory page must be erased by an application before redefining user-defined characters. For more information, see the Erase User Flash Sector (1D 40 *n*) Command earlier in this section.

Flash Memory User Sectors Allocation

This command sets the allocation of flash sectors between user data storage and logos/user defined characters. This allocation is saved in the EEPROM of the printer and is therefore saved across power cycles.

ASCII GS " U n1 n2
Hex 1D 22 55 n1 n2

Default value of n1 01 (see below)
Default value of n2 01 (see below)

Comments: **n1** is the number of 64K sectors used for logos and user defined characters and **n2** is the number of 64K sectors used for user data storage.
 $n1 + n2 \leq 1$ (256K flash memory)
 $n1 + n2 \leq 13$ (1M flash memory)

Related Information:

If $(n1 + n2)$ is greater than the maximum number of sectors available, the command is ignored. Issuing this command with parameters different from current parameters will erase all sectors.

Erase User Flash Sector

Erases a section of user flash memory and sends a carriage return when the operation is complete.

ASCII GS @ n
Hex 1D 40 n

Value of n 31h-32h

n = 31h (ASCII n = 1)

This command erases all 64K Flash memory sectors allocated to user-defined characters and logos storage. Those sectors should be erased in two situations: when the logo definition areas is full and an application is attempting to define new logos, and when an application wants to replace one user-defined character set with another. In both cases, all logos and character set definitions are erased and must be redefined.

n = 32h (ASCII n = 2)

This command erases all 64K Flash memory sectors allocated to user data storage.

Related Information:

See command "Flash Memory User Sectors Allocation "1D 22 55 n1 n2".

Important: While erasing flash memory, all communication is disabled. To provide feedback to the application, the printer responds to the application when the erase is complete. After sending the Erase User Flash Sector (1D 40 n) command, an application should wait for the response from the printer before sending data. Otherwise, data will be lost. If an application is unable to receive data, it should wait a minimum of five seconds after sending the Erase User Flash Sector (1D 40 n) command before sending data.

Initialise printer

ASCII ESC @
Hex 1B 40

Comments This command clears data in the buffer and initialises the printer settings. Single-Wide, Single-High, Non-Rotated, and Left-Aligned characters are set and User-defined characters or logo graphics are cleared.

End of Paper Sensor Management

ASCII US ETX £ *n*
Hex 1F 03 9C *n*

Comments: This command allows to disable the end of paper feature. It is not recommended to use it without contacting a tech support.

- *n*=00 Paper out sensor disabled, paper out status disabled
- *n*=01 Paper out sensor enabled, paper out status enabled
- *n*=02 Paper out sensor disabled, paper out status enabled

Notes: With paper out sensor disabled the feed and print commands will be processed whether paper is present or not
If the paper status is enabled, it is possible to know if the paper is present or not using the status request commands.

Threshold setting (for end of paper sensor)

ASCII GS *s* SOH *n*
Hex 1D 73 01 *n*

Limits $00 \leq n \leq 254 \Rightarrow 0x00h \text{ to } 0xFFh$

Comments This command defines the threshold of the paper end sensor detection. The corresponding equation is:
$$\text{Threshold} = 5V * n/255$$

Ex: To set threshold = 3V, *n* = 153 decimal the command is then: 1D73 01 99

Paper Low Threshold

ASCII GS *s* SOH *n*
Hex 1D 73 06 *n*

Limits $00 \leq n \leq 254 \Rightarrow 0x00h \text{ to } 0xFFh$

Comments This command defines the threshold of the paper low sensor detection. The corresponding equation is:
$$\text{Threshold} = 5V * n/255$$

Autotest

ASCII US t
Hex 1F 74

Comments This command allows the user to perform an AUTOTEST

Voltage and Temperature Monitoring

ASCII US LF n
Hexadecimal 1F 0A n
Decimal 31 10 n

Limits $132 \leq n \leq 133$
 $0x84h \leq n \leq 0x85h$

Comments This command returns the results of latest voltage and temperature measurements. It always returns 7 Bytes: Command ID + zero terminated ASCII string.

RETURNED STATUS DEFINITION <i>n = 0x84: Read Voltage (in Volt)</i>		
Byte	Function	Value
0	Command Id	0x84
1-5	ASCII string	
	End of String	0x00

RETURNED STATUS DEFINITION <i>n = 0x85: Read Print-head Temperature (in °C)</i>		
Byte	Function	Value
0	Command Id	0x85
1-5	ASCII string	
6	End of String	0x00

RS232 Configuration

ASCII US STX *n1 n2 n3 n4 n5 n6*
 Hex 1F 02 *n1 n2 n3 n4 n5 n6*

Comments This command allows the user to configure RS232 port. This command will store the communication options in non-volatile memory. (NVRAM)

Operands: n1 Interface selection
 n2 - n6 Parameters
Default (*) RS232 , 115200, n , 8 , 1

Values (Hex)

n1 : - = x00 = Interface → RS232 (*)
n2 : Bit [0..2] = x03 = Baud rate → 9600
 " " = x04 = Baud rate → 19200
 " " = x05 = Baud rate → 38400
 " " = x06 = Baud rate → 57400
 " " = x07 = Baud rate → 115200 (*)
 " Bit 4 = x00 = Number of stop bits → 1 (*)
 " " = x08 = Number of stop bits → 2
 " Bit 5 = x00 = Number of Data bits → 8
n3 : - = x00 = Parity → Odd
 " - = x01 = Parity → Even
n4 : - = x00 = Parity Mode → No parity (*)
 " - = x01 = Parity Mode → Enable parity
n5 : - = x00 = Handshaking → Xon / Xoff
 " - = x01 = Handshaking → Dtr / Dsr (*)
n6 : - = x00 = Error processing → Ignore (*)
 " - = x00 = Error processing → Print

?P = Parity Error.

?F = Framing Error.

?O = Over run Error.

Notes:

This command will be ignored if one of the parameter is incorrect.

- 1) **This command is processed only in boot mode. If the printer is running in normal mode, send first command "switch to Boot Mode" (1B 5B 7D).**
- 2) **This command must be followed by "Printer Reset" command (1D FF).**

10. TROUBLESHOOTING

10.1. Printing Problems

Problem	Possible Causes	What to Do
Colored stripe on the receipt.	Paper is low.	Change the paper.
Receipt does not come out all the way.	Paper is jammed.	Inspect the knife, and clear any jammed paper.
Printer starts to print, but stops while the receipt is being printed.	Paper is jammed.	Inspect the knife, and clear any jammed paper.
Receipt is not cut.	Paper is jammed.	Inspect the knife, and clear any jammed paper.
	The printer is not configured for a knife.	Contact your authorized service representative.
Print is light or spotty.	Paper roll loaded incorrectly.	Check that the paper is loaded properly.
	Thermal print head is dirty.	Use recommended thermal receipt paper.
	Variations in paper.	Increase print density in “Set Hardware Options” of printer Configuration Menu as needed.
Vertical column of print is missing.	This indicates a serious problem with the printer electronics.	Contact your authorized service representative.
One side of receipt is missing.	This indicates a serious problem with the printer electronics.	Contact your authorized service representative.

10.2. Printer Does Not Function

Problem	Possible Causes	What to Do
Printer does not function when turned on.	Printer not plugged in.	Check that printer cables are properly connected on both ends.
		Check that the host or power supply is getting power.