



THERMAL PRINTING SOLUTIONS

## **A630/A631/A632 PRINTER SERIES**

### **USER MANUAL**

Reference 3106894 Issue F  
May 2005



**AXIOHM**

1, rue d'Arcueil, BP 820  
92542 MONTROUGE CEDEX, FRANCE  
Tel : (33) 1 58 07 17 17, Fax : (33) 1 58 07 17 18  
[www.axiohm.com](http://www.axiohm.com)

<b>EVOLUTIONS</b>
-------------------

<b>Date</b>	<b>Issue</b>	<b>Modifications</b>
10/01	Z	Creation
03/02	A	General update
10/03	B	Update : UL certification
10/03	C	Update : CE certification information and Bluetooth™ ; pages 7, 10 11 and 18
04/04	D	Update : UL verification
07/04	E	Modification of the Bluetooth™ password, page 24
03/05	F	Up date: To add A632 version

## INTRODUCTION

The purpose of the manual is to describe how to use the A630/A631/A632 thermal printer. It also provides you with important information for safe printing and for preventing problems and malfunctions.

**Please read this manual before using the printer.**

## CONTENTS

<b>1</b>	<b>GENERAL OVERVIEW .....</b>	<b>7</b>
<b>2</b>	<b>TECHNICAL SPECIFICATIONS.....</b>	<b>8</b>
<b>2.1</b>	<b>Summary of technical specifications .....</b>	<b>8</b>
<b>2.2</b>	<b>Physical specification .....</b>	<b>10</b>
2.2.1	Dimensions .....	10
2.2.2	Power supply specifications .....	10
2.2.3	A632 version.....	12
<b>2.3</b>	<b>Interface specifications .....</b>	<b>12</b>
<b>2.4</b>	<b>Environmental specifications .....</b>	<b>12</b>
2.4.1	Environmental conditions.....	12
2.4.2	EMI, ESD and Safety .....	12
2.4.2.1	<i>CE FCC C-tick</i> .....	14
2.4.2.2	<i>Safety</i> .....	15
<b>2.5</b>	<b>Operational performance .....</b>	<b>15</b>
<b>3</b>	<b>SETTING UP YOUR PRINTER.....</b>	<b>16</b>
<b>3.1</b>	<b>Getting ready to use the printer.....</b>	<b>16</b>
3.1.1	Unpacking the printer .....	16
3.1.2	Description of printer parts .....	16
3.1.3	Buttons.....	17
3.1.4	LED Indicator .....	17
3.1.5	Cutter .....	17
3.1.6	Connectors (Plugging and connecting your printer).....	18
3.1.6.1	<i>Installing the battery and connecting the interface on portable version</i> .....	18
3.1.6.2	<i>Connecting the power supply and interface on portable and desktop versions</i> .....	19
3.1.6.3	<i>Charging the battery (A631)</i> .....	20
3.1.7	Mounting holes.....	20
3.1.8	Sensors.....	20
<b>3.2</b>	<b>Choosing the proper location for your printer.....</b>	<b>20</b>
<b>3.3</b>	<b>Loading paper .....</b>	<b>21</b>
<b>3.4</b>	<b>Light indicator.....</b>	<b>22</b>
<b>3.5</b>	<b>Connectors &amp; cables .....</b>	<b>22</b>
3.5.1	Power connector .....	22
3.5.2	Communications interface connectors.....	22
3.5.2.1	<i>RS232 Serial Interface</i> .....	23
3.5.2.2	<i>PC → Board Connections</i> .....	23
3.5.2.3	<i>Centronics Interface</i> .....	24
3.5.2.4	<i>A632 Version (automotive 12V)</i> .....	25

3.5.2.5	<i>Centronics timing</i>	26
3.5.2.6	<i>Bluetooth™ interface</i>	26
<b>3.6</b>	<b>Self test description .....</b>	<b>26</b>
<b>3.7</b>	<b>Configuration menu description.....</b>	<b>27</b>
3.7.1	How to enter .....	27
3.7.2	How to move in the program .....	27
3.7.3	How to adjust parameters .....	27
3.7.4	How to quit and save the program .....	27
3.7.5	List of parameters that can be changed.....	28
<b>3.8</b>	<b>Drivers.....</b>	<b>29</b>
<b>4</b>	<b>LIST OF CONTROL CODES .....</b>	<b>30</b>
<b>4.1</b>	<b>Command Summary for Emulation compatible DP1000.....</b>	<b>30</b>
<b>4.2</b>	<b>Command Summary for ESC/POS Emulation (compatible WITH Epson).....</b>	<b>31</b>
<b>5</b>	<b>COMMAND DESCRIPTION.....</b>	<b>33</b>
<b>5.1</b>	<b>Command conventions .....</b>	<b>33</b>
<b>5.2</b>	<b>Command Summary for Emulation compatible DP1000.....</b>	<b>33</b>
5.2.1	Reset commands .....	33
5.2.2	Vertical positioning and print commands.....	33
5.2.3	Horizontal positioning commands.....	35
5.2.4	Print characteristics commands .....	35
5.2.5	Font commands.....	37
5.2.6	Graphics commands.....	37
<b>5.3</b>	<b>Command Summary for ESC/POS Emulation (compatible WITH Epson).....</b>	<b>38</b>
5.3.1	Reset commands .....	38
5.3.2	Vertical positioning and print commands.....	39
5.3.3	Horizontal positioning commands .....	40
5.3.4	Printer configuration.....	41
5.3.5	Print characteristics commands .....	41
5.3.6	Font commands.....	42
5.3.7	Graphics commands.....	45
5.3.8	Printer Status.....	46
5.3.9	Bar code commands.....	50
5.3.10	Flash Firmware Download Commands (RS232 and Bluetooth™ models only) .....	52
5.3.10.1	<i>Firmware Download Sequence</i>	52
5.3.10.2	<i>Commands</i>	53
5.3.11	Configuration commands.....	55

<b>6</b>	<b>STANDARD AND INTERNATIONAL CHARACTER SET.....</b>	<b>58</b>
6.1	Standard: Code Page 437 (modified with euro character at position D5) .....	58
6.2	Additional codes .....	59
<b>7</b>	<b>TROUBLE SHOOTING.....</b>	<b>60</b>
7.1	Problems and solutions.....	60
<b>8</b>	<b>CLEANING YOUR PRINTER.....</b>	<b>61</b>
8.1	Cleaning the printer.....	61
8.2	Cleaning the print head .....	61
<b>9</b>	<b>WARRANTY .....</b>	<b>62</b>
<b>10</b>	<b>ACCESSORIES.....</b>	<b>63</b>

## 1 GENERAL OVERVIEW

The A630, A631 and A632 are versatile Clamshell™ (*Easy paper loading*) thermal printers, designed for desktop or portable use.

The A632 version is a version dedicated to automotive applications (taxis...).

By following the guide lines in this manual and with careful handling, a long and reliable operating life can be expected from these printers.

Please note that portable versions are provided with uncharged batteries for safety and storage reasons.

Main features:

- International character set
- Automatic power-off features
- Self-test facility
- Graphics
- Reset command
- Emulation Choice
- Bar Code Printing
- User defined character set

## 2 TECHNICAL SPECIFICATIONS

### 2.1 Summary of technical specifications

ITEM		VALUE	UNITS
Printing method		Static thermal dot line printing	-
Paper loading		Clamshell™	-
Number of resistor dots		384	-
Resolution		8	dots/mm
Printing width		48	mm
Printing speed		55 (desktop version) max 45 (portable version) max	mm/s
Character Fonts		16 x 24 dots. (24 columns) or 9 x 24 (40 columns)	-
Paper width		58 ± 0.1	mm
Paper bucket diameter		50	mm
Data Buffer		4	K bytes
Head temperature detection		Thermistor	-
Paper empty detection		Opto-sensor	-
Printer voltage range: A630/A631 A632		9 VDC or 110/240 with power supply 10.6 to 16	- V
Power consumption		23	VA
Power supply		110/240 50 - 60	V Hz
Maximum duty cycle (in case of non-stop use)		1 sec. On, 6 sec. Off at 20° C 1 sec. On, 8 sec. Off at 50° C	°C
Storage temperature range: A630/A631 A632		-20 to 50 -20 to 70	°C
Operating temperature range		5 to 50	°C
Operating humidity		10 to 85	% RH (Non-Condensing)
Storage humidity		10 to 90	% RH (Non-Condensing)
Electrical life time		50	million head pulses per dot
Mechanical life time (abrasion)		50	Km
Over all dimensions:	Width	108	mm
	Depth	147	mm
	Height	72	mm
Weight ( Without paper roll )		330 or 600 (with battery)	g
Recommended paper		TF50KSE3	-
Maximum paper thickness		80	μ
Interface		RS232 Serial Centronics Bluetooth™	-
Certification:	EMI	CE; FCC; C-tick ; UL / cUL; Bluetooth™	-
	Safety	UL / cUL; IEC 60950	-

ITEM	COMMENTS
Vibration:	<p><b><u>Sinusoidal vibration tests</u></b>            The standard used for this test was : IEC68-2-6            5-9 Hz, 6 mm displacement            9-200 Hz, 1g of accélération.            1 octave / minute            12 cycles per axis            3 axes            Printer unpacked and operating</p> <p><b><u>Random vibration tests</u></b>            The standard used for this test was : IEC 68-2-36            5-200 Hz, DSP : 0.01 g<sup>2</sup>/Hz            200-500 Hz, DSP : 0.003 g<sup>2</sup>/Hz.            mean acceleration : 1.7 g            Duration : 30min per axis            3 axes            Printer unpacked and operating</p> <p><b><u>Shake vibration tests</u></b>            The standard used for this test was : IEC 68-2-29            Wave : half sinusoidal            Acceleration : 15 g            Duration : 6 ms / 500 buffets            6 axes (±OX, ±OY, ±OZ)</p>

## 2.2 Physical specification

### 2.2.1 Dimensions

<b>Height</b>	72 mm
<b>Width</b>	108 mm
<b>Depth</b>	147 mm
<b>Weight (with cutter)</b>	330 g 600 g (with battery)

### 2.2.2 Power supply specifications (A630 – A631 only)

#### 1) Without Battery Pack

For desktop models, without batteries, a supply of 9 VDC is required. The current rating of the supply will depend on the print duty (More black print - more current) but typically a 9v supply at 2.5A will suffice for most applications.

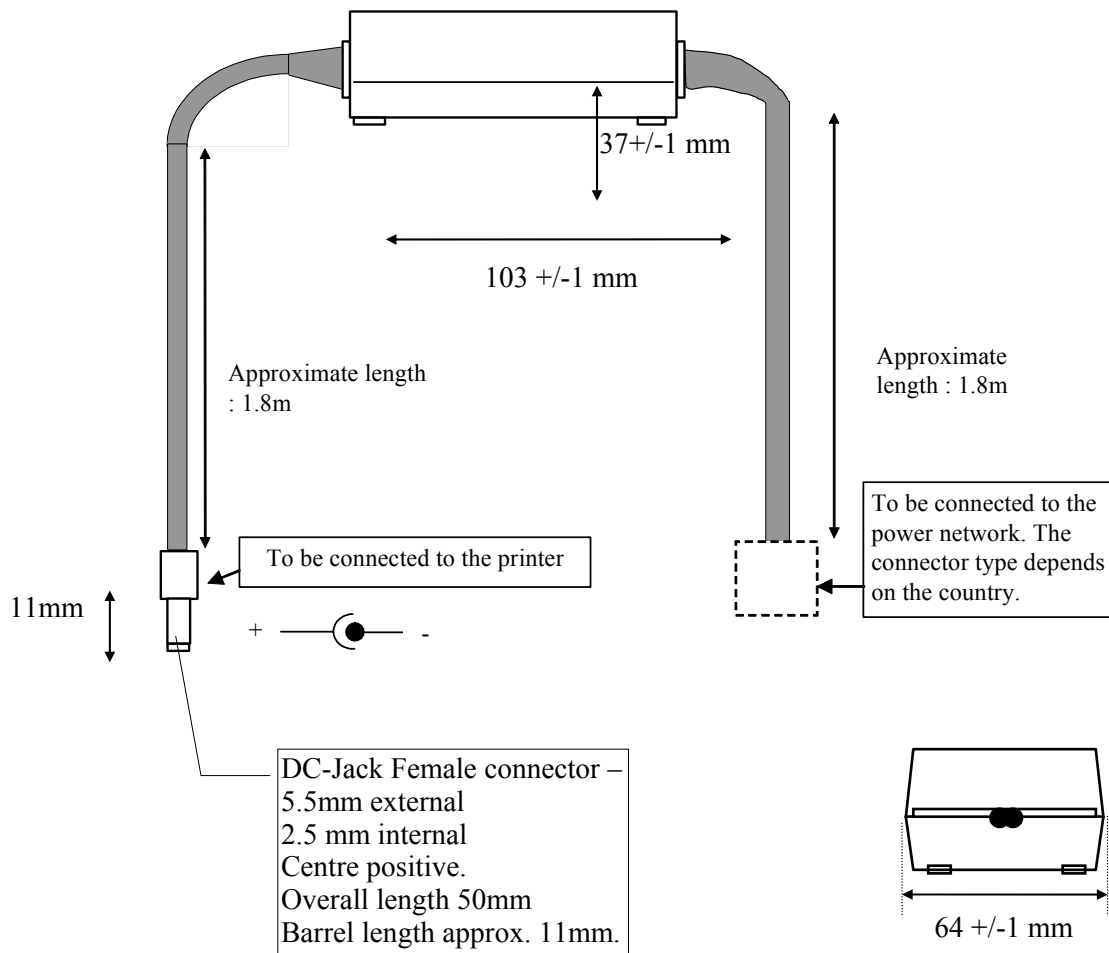

**Remark:** power supply 50 VA

- **INPUT** : 230 VAC 50Hz
- **OUTPUT** : 9VDC 2500mA

**Regulations :      CE                      UL                      CSA                      GS**

**Note:** The power supply should be a “SELV” type in order to meet safety standards.

## 2) With Battery Pack

External, replaceable battery pack, AXIOHM reference 3106282 (Kit reference: 3106880).

Approximately 80m of text (25% pts on at 25°C) can be printed with a full battery.

It will take 1.30 hours (without printing) to totally charge the battery via the printer.

A optional power saving ("Power Mode") feature automatically switches the printer off when the interface has not been used for 5 minutes period (Power mode = ON).

**Caution:** Danger of explosion if battery is incorrectly replaced. Replace only with the same or equivalent type recommended by the manufacturer. Dispose of used batteries according to the manufacturer’s instructions.

Specifications: Nickel-Cadmium rechargeable

<b>Nominal Voltage</b>	6.0 V
<b>Rated Capacity</b>	1200 mAh
<b>Average Weight</b>	182 g (6.4 oz.)
<b>Maximum Volume</b>	78 cm <sup>3</sup> ( 4.8 in <sup>3</sup> )
<b>Terminals</b>	Flat
<b>Operating Temperature Range</b>	-20 °C to +50 °C (-4 °F to 122 °F)

**Important:** AXIOHM cannot guarantee the correct operation of the printer if another power supply is used other than an AXIOHM power supply.

The nominal voltage is 12V (operating range: 10.6V – 16V). To power the printer, use a cable able to handle the max current value and protect the installation by using a 12V/10A max. fuse, suited for automotive applications.

Note – Axiohm will not provide neither the cable nor the fuse.

### 2.3 Interface specifications

See chapter "Communications interface connectors".

### 2.4 Environmental specifications

#### 2.4.1 Environmental conditions

<b>Operating temperature:</b>	5 to 50 °C
<b>Storage temperature: A630/A631</b>	-20 to 50 °C
<b>A632</b>	-20 to 70 °C
<b>Maximum humidity:</b>	10 to 90 % RH (non-condensing)

**Vibration** Details upon request : consult AXIOHM's Technical Support Team.

**Drop test** The printer is packed.  
1 meter on concrete  
1 meter on wood

#### 2.4.2 EMI, ESD and Safety

##### Conditions of acceptability:

EMI is measured using AXIOHM power supply adapter ref. **3106262**. UL valid only if the proper power supply (AXIOHM part n° **3106175**) and the proper batteries (AXIOHM part n° **3106282**) are used.

**Note:** The available replacement kits are:

- ref. **3106935** A630/A631/A632 POWER SUPPLY KIT EU for the power supply
- ref. **3106880** BATTERY KIT A631 for the batteries.

**Safety recommendations:** The power supply should be installed so it can be accessed in order to enable power disconnection.

A630/A631 is designed to meet the requirements of:

CE

FCC

C-tick for Australia

UL / cUL

Bluetooth<sup>TM</sup> (These products are in conformity with the 1999-5-CE directives.

A certificate of compliance is available upon request from Axiohm.)



A632: automotive "e" marking. European directive 95/54/CE

2.4.2.1 CE FCC C-tick

**Note for Class A products only:** This equipment has been tested and found to comply with the limits for a Class A digital device, pursuant to Part 15 of the FCC Rules. These limits are designed to provide reasonable protection against harmful interference when the equipment is operated in a commercial environment. This equipment generates, uses, and can radiate radio frequency energy and, if not installed and used in accordance with the instruction manual, may cause harmful interference to radio communications. Operation of this equipment in a residential area is likely to cause harmful interference, in which case the correction of the interference required will be at the user's expense. Pursuant to Part 15.21 of the FCC Rules, any changes or modifications to this equipment not expressly approved by AXIOHM may cause, harmful interference and void the FCC authorization to operate this equipment.

<b>Concerning products:</b>	
<b>A630/A631 FCC, CE Class A</b>	A630Yxxx
	A631Yxxx
<i>Y = all versions except where the fifth digit is 2</i>	
<b>A630/A631 Bluetooth™ FCC Class B, CE Class B</b>	A6302xxx
	A6312xxx

**FCC ID : RCAA631BT**

**Information to the user, for Class B products only:**

The United States Federal Communications Commission (in 47 CFR 15.105) has specified that the following notice be brought to the attention of users of this product:

This equipment has been tested and found to comply with the limits for a Class B digital device, pursuant to part 15 of the FCC Rules. These limits are designed to provide reasonable protection against harmful interference in a residential installation. This equipment generates uses and can radiate radio frequency energy and, if not installed and used in accordance with the instructions, may cause harmful interference to radio communications. However, there is no guarantee that interference will not occur in a particular installation. If this equipment does cause harmful interference to radio or television reception, which can be determined by turning the equipment off and on, the user is encouraged to try to correct the interference's by one or more of the following measures:

- Reorient or relocate the receiving antenna.
- Increase the separation between the equipment and the receiver.
- Connect the equipment into an outlet on a circuit different from that to which the receiver is connected.
- Consult the dealer or an experienced radio/TV technician for help.

The user may find the following booklet, prepared by the Federal Communications Commission, helpful: How to Identify and Resolve Radio/TV Interference Problems. This booklet is available from the U.S. Government Printing Office, Washington, D.C. 20402, Stock No. 004-000-00345-4.

Use of a shielded cable is required to comply within Class B limits of Part 15 of FCC Rules.

Pursuant to Part 15.21 of the FCC Rules, any changes or modifications to this equipment not expressly approved by AXIOHM may cause, harmful interference and void the FCC authorization to operate this equipment.

#### 2.4.2.2 Safety

UL / cUL

This printer is to be powered by a SELV circuit only.  
The communication connectors must be of SELV type only.

### 2.5 Operational performance

Paper specification

<b>Paper width</b>	58 mm
<b>Maximum paper roll diameter</b>	50 mm
<b>(Maximum paper roll length)</b>	m (using 60gsm paper)
<b>Recommended papers</b>	AXIOHM ref of KP 640
<b>Emulsion (sensitive) side</b>	On outer side of roll

\* You must contact AXIOHM if you wish to use an alternative type of paper; otherwise your warranty might not be valid and you could cause damage to your printer.

## 3 SETTING UP YOUR PRINTER

### 3.1 Getting ready to use the printer

#### 3.1.1 Unpacking the printer

The printer comes in a plain cardboard carton with a reusable packing foam insert and separate pockets for:

- One printer
- One set-up guide
- One single 80m roll of thermal paper
- One standard power supply (except A630/631xxxx - 500) for desktop versions
- One power cable for connecting to the printer and to the power network, with appropriate mains plug for the country of sale
- One communication cable on portable versions
- One battery on portable versions

The model number and serial number (including manufacturing week and batch number) of the printer will be marked on the exterior of the packaging.

Make sure that no parts are missing or damaged. Report any deficiency to your supplier as soon as possible after receiving the printer. The original packaging material should be kept to transport or return your printer, if necessary.

#### 3.1.2 Description of printer parts

The A630 / A631 are complete printers designed with the Clamshell™ easy paper loading system. A631 are portable versions, but can be used while connected to a power supply for battery charging.

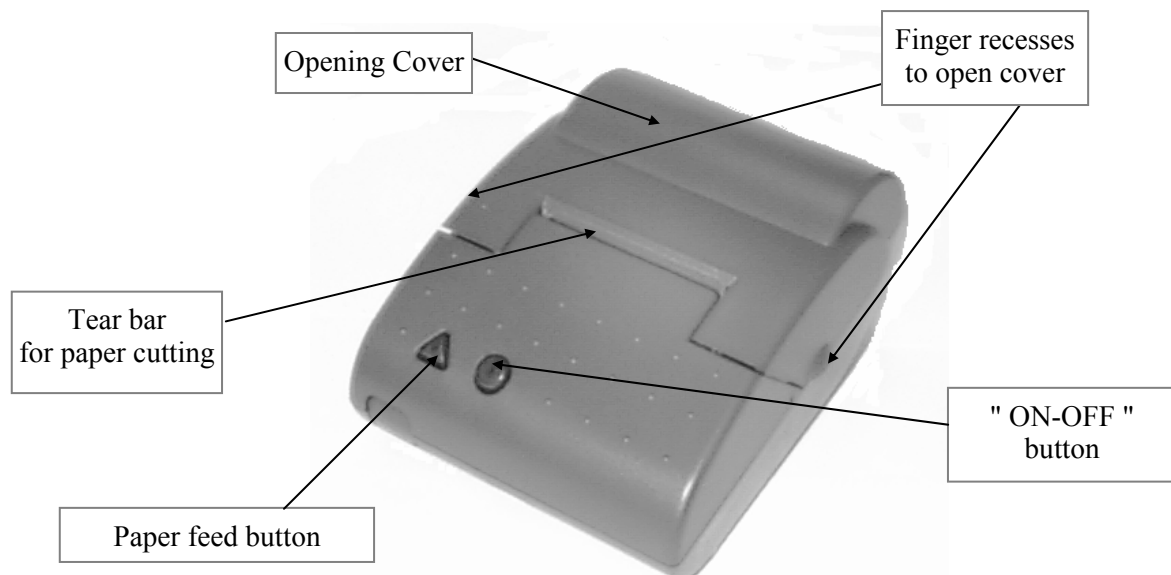

## Rubber boot

It can be added to protect your printer for portable applications (A631). This protection is designed to be easily attached to the user belt.

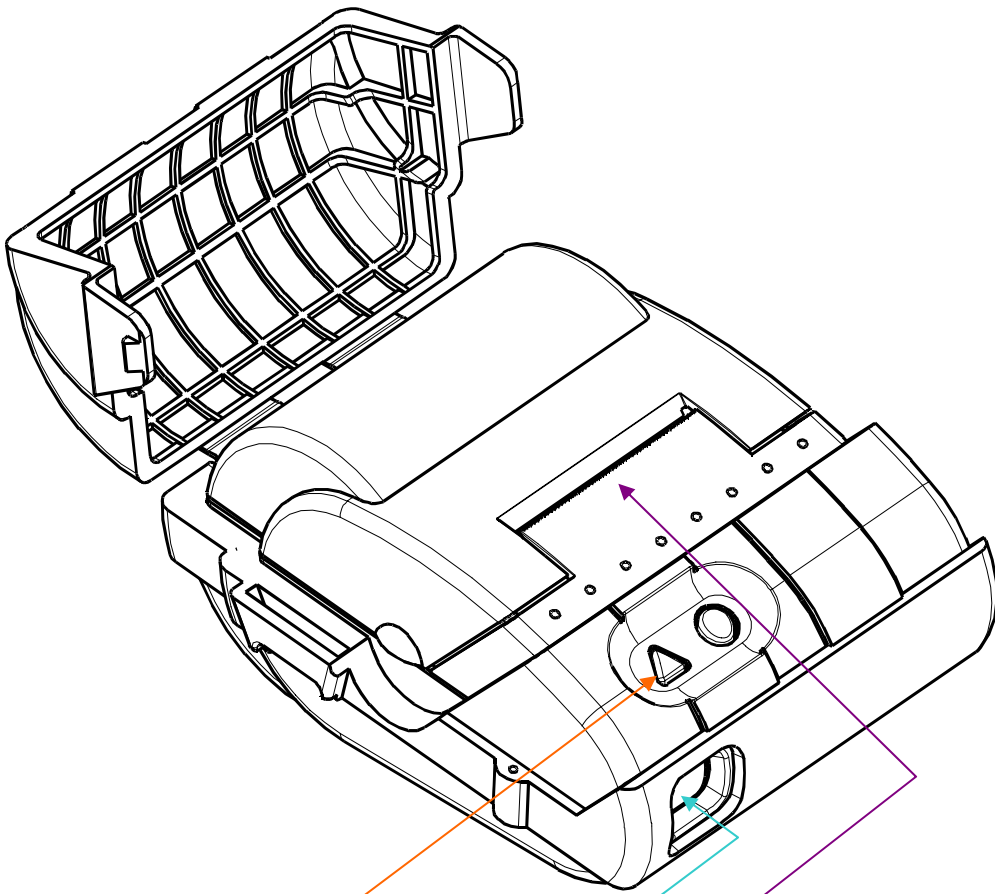

3.1.3 Buttons

Off  
Paper feed

3.1.4 LED Indicator

Power On  
Error

3.1.5 Cutter

Tear bar cutter

## 3.1.6 Connectors (Plugging and connecting your printer)

**Note:** Connecting the interface is not applicable for Bluetooth™ versions.

### 3.1.6.1 Installing the battery and connecting the interface on portable version

The battery is set underneath the printer as shown here after and clipped to the printer: push to clip, pull to unclip.

A locating pin will prevent you from inserting the battery in the wrong direction.

If you feel any resistance when trying to clip the battery into place, verify that it is in the proper direction.

If not, turn the battery and try again.

Take care not to apply too much pressure while inserting the battery, as you might break the locating pin.

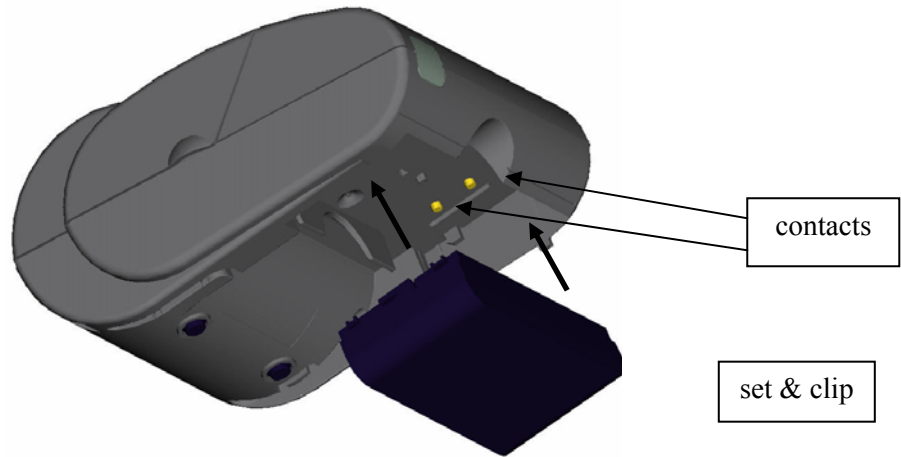

Set your interface cable at the rear of the printer to the connector shown here after.

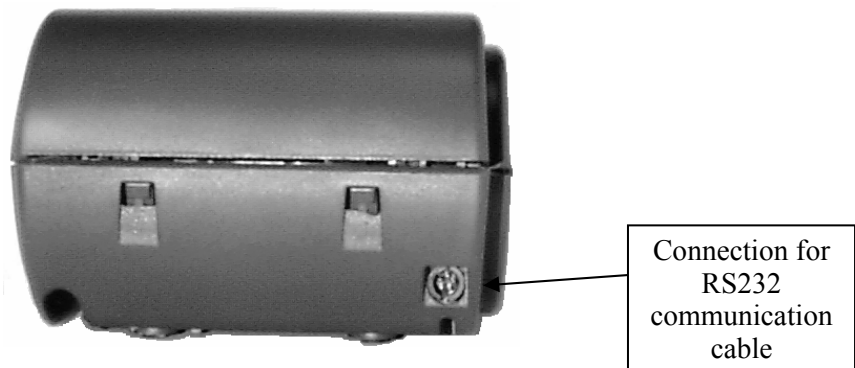

## 3.1.6.2 Connecting the power supply and interface on portable and desktop versions

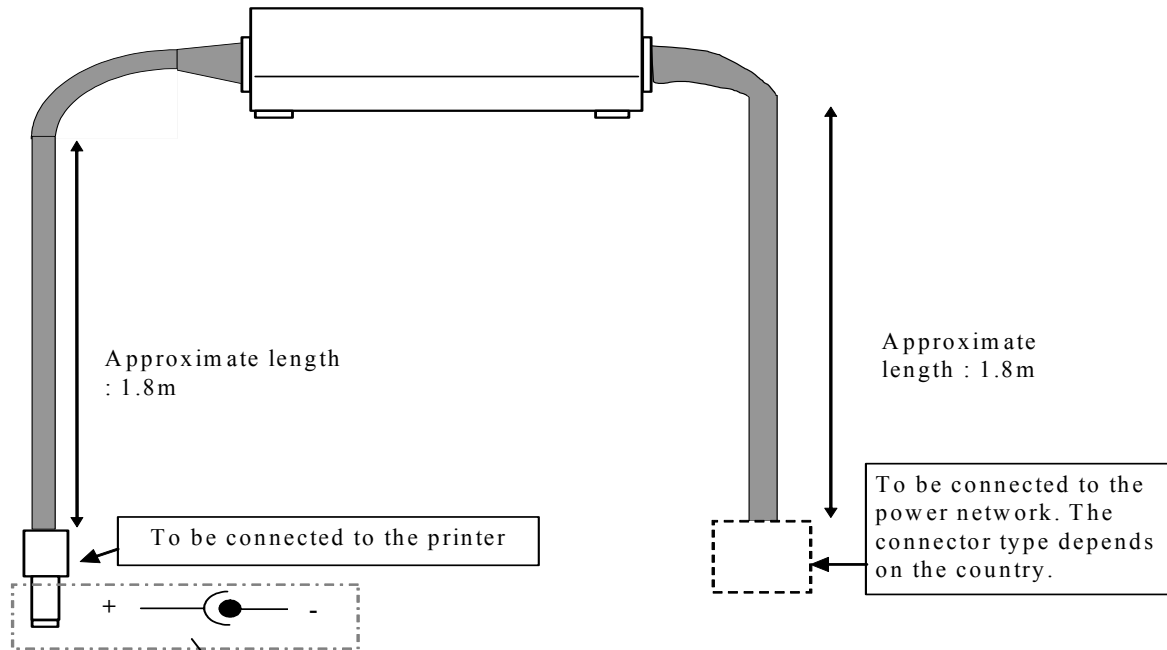

**Desktop version:**  
Connect the interface cable with the DB25 connector

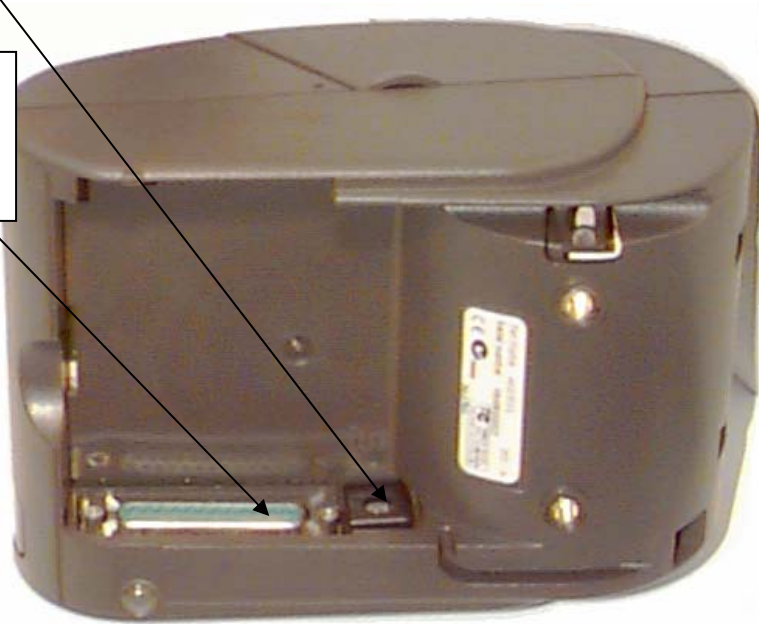

**Safety recommendation:** The power supply should be installed so it can be accessed in order to enable power disconnection.

### 3.1.6.3 Charging the battery (A631)

When the battery is low, the green led flashes slowly. The printer stops when the battery is empty.

The charge begins when the printer is connected to the power supply: the green led flashes rapidly. When fully charged, it stops automatically (charging time is about 1h 30 min).

Recommendation:

- Never try to re-charge a full battery, you could damage it.
- The charge cannot start if the cover is open or if there is no paper in the printer (red led flashing).
- When not using the printer for more than 24 h, unclip the battery from the printer. This will prevent the battery from discharging.

Printing while charging the battery is possible, but the charge stops while printing

### 3.1.7 Mounting holes

Two (2) holes based underneath the printer under the rubber feet.

### 3.1.8 Sensors

The A630/A631 printer is fitted with two (2) sensors, which detect abnormal conditions:

Door-closed sensor:

End-of-paper (EOP) sensor:

## 3.2 *Choosing the proper location for your printer*

The A630/A631 printer may be used in a variety of applications; but, to maintain optimum working conditions from your unit, the following recommendations should be followed:

- Avoid dirty or dusty locations, the risk of water exposure, excessive heat or humidity (temperature from 5 to 50°C for operating or -20 to 50 for storage) and mechanical stress.
- Choose a stable level base on which to place the printer.
- Make sufficient space around the printer to ensure comfort while using your printer, including sufficient access to open the lid while changing paper.

It is recommended to avoid mechanical vibrations

## 3.3 Loading paper

The Clamshell™ design allows easy paper loading.

### To load paper:

Refer to the illustrations while following these steps:

- Open the cover using finger recesses.
- Set the paper roll as indicated on the picture below by pushing aside the right roll support.
- Close the cover leaving a small length of paper out.
- Cut the small length left with the tear bar. Your paper roll is set.

### Note:

The paper used should be recommended by AXIOHM  
The paper width must be 58 mm  
The maximum paper roll diameter is 50 mm

### Warning:

- 1) Close the cover by pushing the two sides simultaneously.
- 2) It is possible to load the paper when the printer is powered (*On*). In this case, check if it is still powered (*On*) after closing the cover; if not, press the On/Off button.

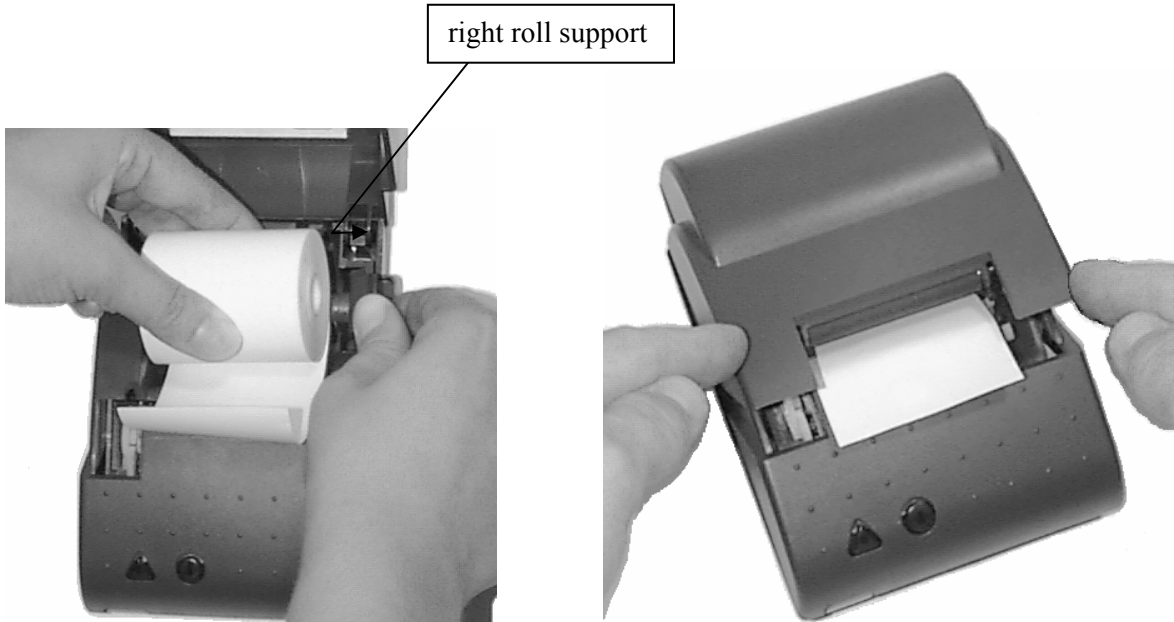
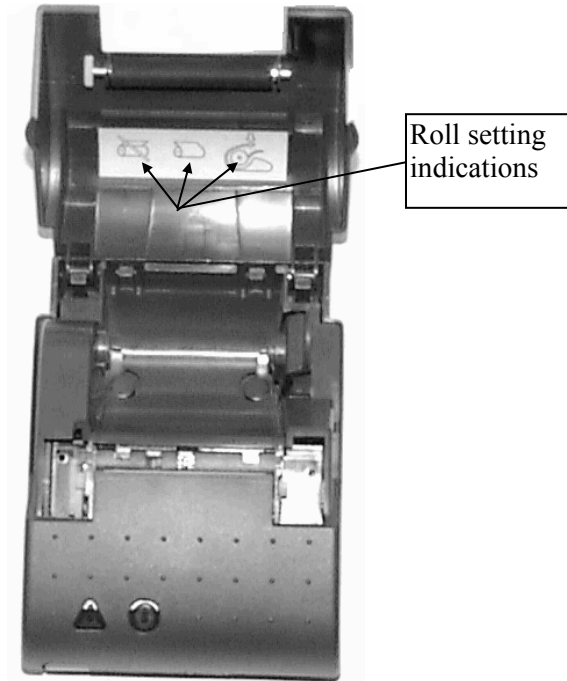

### 3.4 Light indicator

When the printer is turned "off", the button is not lit.

When the printer is set "on", the "on-off" button flashes (red) for a few seconds, and then turns off. The Paper feed button lights up (green); the printer can receive data and print.

### 3.5 Connectors & cables

To reduce the electromagnetic emissions and susceptibility, all cables should be screened. If you are not using cables supplied by AXIOHM for this purpose, please ensure that your cables match the printer and are rated at the appropriate voltage and current capacities.

**\*Use of an inappropriate cable may seriously damage your printer!**

#### 3.5.1 Power connector

#### 3.5.2 Communications interface connectors

The A630 printers are available as standard with RS232 Serial interface or Centronics interface (desktop version only).

The interface type is printed on the self-test slip.

The connector is a 25 way D socket for desktop model.

The connector is a Binder 5 for portable model.

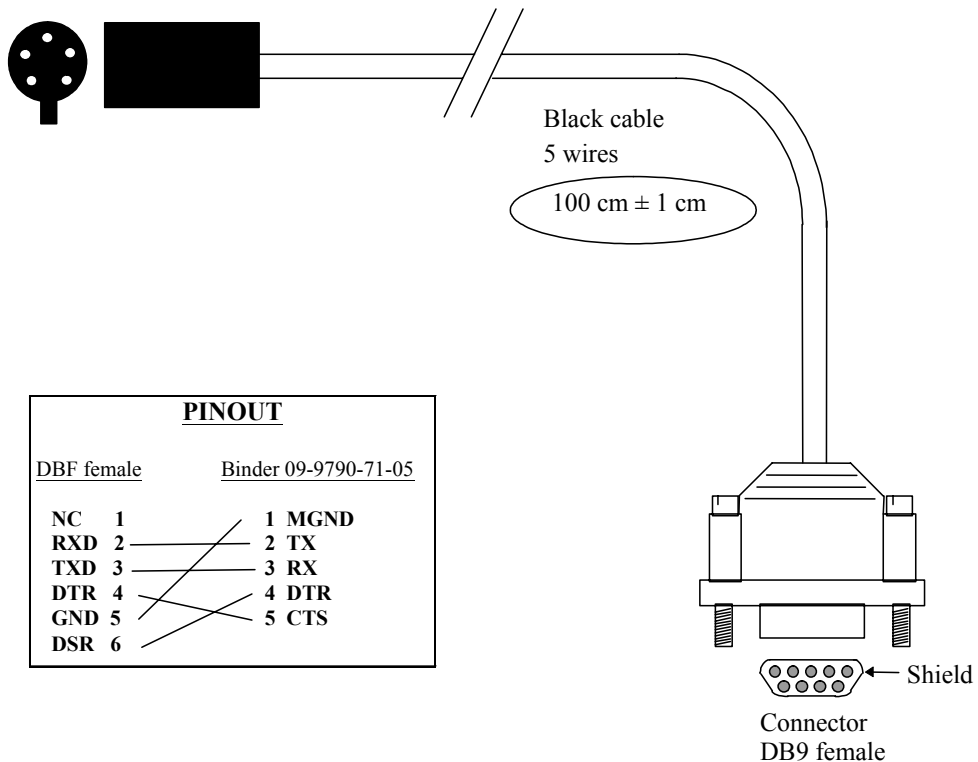

### 3.5.2.1 RS232 Serial Interface

A630 (25 Way D Socket)			A631 (Binder)		
Function	Connector Pinout	Input / Output	Function	Connector Pinout	Input / Output
RX	3	IN	RX	3	IN
TX	2	OUT	TX	2	OUT
CTS	5	IN	CTS	5	IN
DTR	20	OUT	DTR	4	OUT
GND	7	-	GND	1	-
NC	6,8-19,21-25	-	NC	-	-
FG	1	-	FG	-	-
RTS	4 (+10V via 1K)	OUT	RTS	-	OUT

### 3.5.2.2 PC → Board Connections

A630			A631		
25 Way D Socket	→	PC	Binder	→	PC
Pins: 3	→	3 ( TX )	Pins: 3	→	3
2	→	2 ( RX )	2	→	2
5	→	4 ( DTR )	5	→	4
20	→	6 ( DSR )	4	→	6
7	→	5 ( GND )	1	→	5

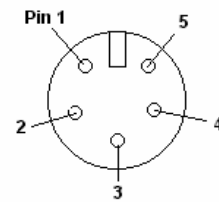
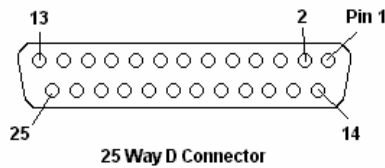

Ref. 09-9792-30-05-5

### 3.5.2.3 Centronics Interface

630 ( 25 Way D Socket )		
Connector Pinout	Function	Input / Output
1	C_STROBE	IN
2	D0	IN
3	D1	IN
4	D2	IN
5	D3	IN
6	D4	IN
7	D5	IN
8	D6	IN
9	D7	IN
10	C_ACKNO	OUT
11	C_BUSY	OUT
12	C_PE	OUT
13, 14, 17	NC	/
15	C_ERROR	OUT
16	C_INIT	IN
18 → 25	GND	/

## 3.5.2.4 A632 Version (automotive 12V)

Power:

- A6320000: coaxial connector
- A6320001: DB25 connector.

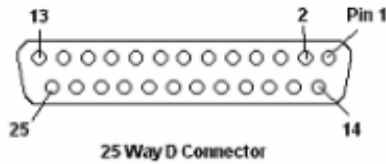

632 ( 25 Way D Socket )		
Connector Pinout	Function	Input / Output
1	GND LOGIC	/
2	TXD	OUT
3	RXD	IN
4	NC	/
5	CTS	IN
6	NC	/
7	GND LOGIC	/
8,9	GDN POWER SUPPLY*	/
10,11	NC	/
12,13	+ POWER SUPPLY (12V)*	/
14,15	GDN POWER SUPPLY*	/
16,17	+ POWER SUPPLY (12V)*	/
18,19	NC	/
20	DTR	OUT
21=>25	NC	/

\* A6320010 version only.

## 3.5.2.5 Centronics timing

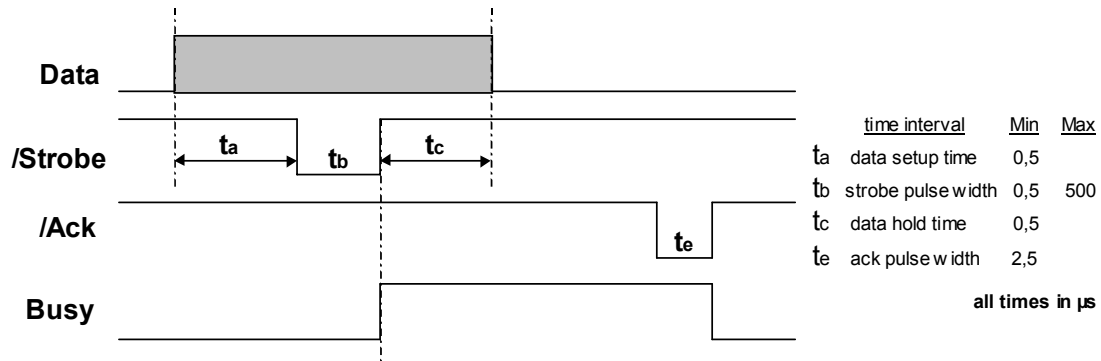

## 3.5.2.6 Bluetooth™ interface

Uses internal antenna, therefore there is no communication interface connector for Bluetooth™ model.

The A631 Bluetooth™ model supports the Serial Port Profile, and it can be used as a serial printer, with Bluetooth™ being used in a cable replacement configuration, for example.

The interface is compatible with Bluetooth™ standard V1.1.

Each printer has a specific User Name that will allow to address an identified printer amongst a batch. This User Name is: A630- + "printer serial number".

A password is necessary to pair and access to the service and enable the connection. This password is: 631200.

The maximum communication throughput is 115200 Baud.

The printer automatically goes in power save mode after 5 minutes without activity, and switches Off the Bluetooth™ link.

The printer needs to be manually turned On using the power On/Off button for Bluetooth™ communication to be re-established.

## 3.6 Self test description

**Note:** Before printing a first ticket on the portable version, you have to load the battery (see above)

To print a self test ticket, follow the next instructions:

- If the printer is "On" set it "Off" by pushing the "ON/OFF" button.
- Activate both the Paper feed button and the ON/OFF button.
- Keep the paper feed button pressed and release the ON/OFF button.
- When the ticket starts, release the Paper feed button.

When resetting the printer, all running operations are stopped and all information sent before resetting will be lost.

## 3.7 Configuration menu description

**Program mode:** The program switch may be accessed by keeping pressed the paper feed button during the self test.

### 3.7.1 How to enter

To enter the program mode:

Power down the printer

Press the power button and the paper feed button together

Release the power button, keep the paper feed button pressed until the text “A630 configuration menu” is printed.

### 3.7.2 How to move in the program

To move in the list of the parameters do a short click on paper feed button.

A long click allows selecting the parameter you want to change.

Then a short click allows you to move in the possible choices for that parameter. Do a long click to validate the choice.

### 3.7.3 How to adjust parameters

For default parameters, see "Self test" chapter.

### 3.7.4 How to quit and save the program

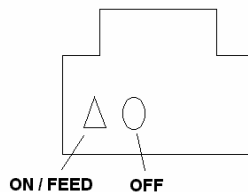

When all the necessary changes to the parameters have been made, select the parameter “END” and validate with a long click.

A new long click is asked, and then the printer has to be reset.

### 3.7.5 List of parameters that can be changed

Parameter (short click on paper feed)	Status
(1) Interface	RS232 Bluetooth™
(2) Graphics	Hi-Res Standard ESC_POS
(3) Baud Rate	1200 baud 2400 baud 4800 baud 9600 baud 19200 baud 38400 baud 57600 baud 115200 baud
(4) Parity	No Yes
(5) Parity type	Odd parity Even parity
(6) Number of data bits	8 bit data 7 bit data
(7) Stop	1 2
(8) Protocol	DTR/DSR XON/XOFF
(9) Brightness	60-130 60 is lightest (100 default) 130 is darkest
(10) Emulation	DP1000 / DP1200 ESC/POS
(11) Power Mode	ON OFF
(12) Country	USA **      ITALY FRANCE      SPAIN GERMANY      JAPAN UK      NORWAY DENMARK 1      DENMARK 2 SWEDEN
(13) Font set	16 * 24 9 * 24

(only value allowed with Bluetooth™)

(not available with Bluetooth™)

### 3.8 Drivers

Function description for printer driving

*Default settings:*

A630000E	A631xxxx
Data bits 8 Parity None Baud Rate 115 200 Country U.S.A Power mode Off Emulation : Compatible ESC_POS DTR / DSR Font set 16*24 Graphics Standard Brightness 100	Data bits 8 Parity None Baud Rate 115 200 Country U.S.A Power mode On (5min) Emulation : Compatible ESC_POS DTR / DSR Font set 16*24 Graphics Standard Brightness 100

A632xxxx
Data bits 8 Parity None Baud Rate 115 200 Country U.S.A Power mode On Emulation : Compatible ESC_POS DTR / DSR Font set 16*24 Graphics Standard Brightness 100

## 4 LIST OF CONTROL CODES

Hex Command	Description	Page
1F 01 <i>n</i>	select emulation	55

### 4.1 Command Summary for Emulation compatible DP1000.

#### Reset commands:

Hex Command	Description	Page
11	Reset	33

#### Vertical positioning and print commands:

Hex Command	Description	Page
0A	Feed on line	33
0B	Form / Label feed	33
0C <i>n</i>	Vertical tab	34
0D	Carriage return	34
1B 33 <i>n</i>	Set line spacing	34

#### Horizontal positioning commands:

Hex Command	Description	Page
09	Horizontal tab	35

#### Print characteristics commands:

Hex Command	Description	Page
0E	Double width	35
0F	Single width	35
15	Underline "ON"	36
18	Underline "OFF"	36
19	Reverse print	36
1A	Double height	36

#### Font commands:

Hex Command	Description	Page
1C	24 Columns font	37
1D	42 Columns font	37

#### Graphics commands:

Hex Command	Description	Page
1B <i>n d1</i> -> <i>d24</i>	Standard graphics	37
1B 4B <i>n1 n2</i>	Epson graphics	38

## 4.2 Command Summary for ESC/POS Emulation (compatible WITH Epson)

### Reset commands:

Hex Command	Description	Page
1B 40	Initialize printer	38
1D FF	Printer reset	38

### Vertical positioning and print commands:

Hex Command	Description	Page
0A	Line feed	39
0C	Form feed	39
0D	Carriage return	39
1B 33 <i>n</i>	Set line spacing	34
1B 43 <i>n</i>	Set form length	40
1B 64 <i>n</i>	Print & feed	40

### Horizontal positioning commands:

Hex Command	Description	Page
09	Horizontal tab	40
1B 24 <i>n1 n2</i>	Set print starting position	40

### Printer configuration commands:

Hex Command	Description	Page
1F 74	Print self-test	41

### Print characteristics commands:

Hex Command	Description	Page
1B 21 <i>n</i>	Set print mode	41
1B 7B <i>n</i>	Inverted printing	41

### Font commands:

Hex Command	Description	Page
1B 25 <i>n</i>	Set / Cancel user-defined characters	42
1B 26 <i>s n m data</i>	Define user-defined characters	42
1B 52 <i>n</i>	Select international character set	44

### Graphics commands:

Hex Command	Description	Page
11 <i>n1 ... n1</i>	Graphic printing mode	45
1B 2A <i>m n1 n2</i>	Bit image graphics	46

**Printer Status commands:**

Hex Command	Description	Page
1B 76	Status request	46
1D 08	Read SRAM size	47
1D 49 <i>n</i>	Transmit printer ID	47
1D 49 40 <i>n</i>	Transmit printer ID, remote diagnostics extension	48
1F 0A 84	Read voltage	49
1F 0A 85	Read print head temperature	49
1F 56	Return firmware revision	49

**Bar code commands:**

Hex Command	Description	Page
1D 48 <i>n</i>	Set HRI print position	50
1D 66 <i>n</i>	Select HRI font	50
1D 68 <i>n</i>	Set bar code height	50
1D 6B <i>m dl...dk</i> NUL	Print bar code (mode 1)	51
1D 6B <i>m n dl...dn</i>	Print bar code (mode 2)	51
1D 77 <i>n</i>	Set bar code magnification	51

**Firmware downloads commands:**

Hex Command	Description	Page
1B 5B 7D	Switch to flash download mode	53
1D 01	Return flash memory size	53
1D 02 <i>nn</i>	Select flash memory sector to download	53
1D 06	Get flash firmware CRC status	54
1D 07	Return boot sector CRC	54
1D 0E	Erase all flash contents except boot sector	54
1D 0F	Return main program flash CRC	54
1D 10 <i>n</i>	Erase selected flash sector	55
1D 11 <i>al ah cl ch dl...dn</i>	Download to active flash sector	55

**Configuration commands:**

Hex Command	Description	Page
1F 01 <i>n</i>	Select emulation	55
1F 02 <i>n1..n6</i>	Set communication parameters	56
1F 0B 4E 52 4A <i>n</i>	Print density	57
1F 0D 43 4C 45 <i>n</i>	Reset EEPROM	57

## 5 COMMAND DESCRIPTION

### 5.1 Command conventions

The following information describes how each command is organized:

**Command Name:** A descriptive name (not the ASCII code) used to identify the command.

**ASCII** the ASCII control code

**Hexadecimal** the Hexadecimal control code

**Comments** A brief summary of the command, followed by more detailed information, if necessary.

### 5.2 Command Summary for Emulation compatible DP1000.

#### 5.2.1 Reset commands

---

##### RESET

---

**ASCII** DC1

**Hexadecimal** 11

**Comments:** This command causes printer status reset. Printer status is set to single width, normal height, and no underline. Note that the buffer remains unaltered to avoid any data loss.

#### 5.2.2 Vertical positioning and print commands

---

##### FEED ONE LINE

---

**ASCII** LF

**Hexadecimal** 0A

**Comments:** This command prints and moves the printing position to the beginning of the next line. If LF and CR are sent, the CR is ignored to avoid a double feed.

**Ex:** 41 41 41 41 41 0A 41 41 41  
⇒ AAAAA  
AAA

---

##### FORM / LABEL FEED

---

**ASCII** VT

**Hexadecimal** 0B

**Comments:** This command will feed 5 fast line feeds in normal mode.

---

**VERTICAL TAB**

---

<b>ASCII</b>	FF
<b>Hexadecimal</b>	<b>0C <i>n</i></b>

**Comments:** This command fast feeds the paper by *n* lines where *n* is a single byte hex number in the range  $0 < n < 63$ . Note that a vertical tab will print the contents of the line buffer before being executed.

---

**CARRIAGE RETURN**

---

<b>ASCII</b>	CR
<b>Hexadecimal</b>	<b>0D</b>

**Comments:** This command prints the current line and feeds one line. If CR and LF are sent, the LF is ignored to avoid a double feed. On the receipt of the last printable character, the printer will automatically print the data in the buffer. If CR and LF are sent after this condition, they will be ignored.

---

**SET LINE SPACING**

---

<b>ASCII</b>	ESC 3 <i>n</i>
<b>Hexadecimal</b>	<b>1B 33 <i>n</i></b>

**Comments:** This command sets the line spacing to  $n/406$  of an inch. Minimum line spacing is 7.5 lines per inch. The line equals the character height when  $n < m$  (typical  $m = 27$ ).

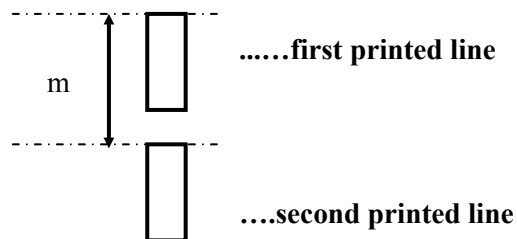

## 5.2.3 Horizontal positioning commands

### HORIZONTAL TAB

---

ASCII	HT
Hexadecimal	09

**Comments:** This command moves the printing position to the next horizontal tab position. Tab stops occur at every 8th column. On receipt of this command, spaces are entered into the line up to the next tab stop.

Ex:    **09** 41 41 41 41 41 41 41 41 41

⇒        \_ \_ \_ \_ \_ \_ \_ \_ \_ \_ AAAAAAAAAA

## 5.2.4 Print characteristics commands

### DOUBLE WIDTH

---

ASCII	SO
Hexadecimal	0E

**Comments:** This command turns double width printing on. This state continues until terminated by the single width command or completion of the current line. If the last character in the line buffer is double width but there is only room for a single width character, then it will be printed in single width.

Ex:    41 41 41 41                    **0E** 41 41 41 41

⇒        AAAA                    ⇒        AA-AA-AA-AA

### SINGLE WIDTH

---

ASCII	SI
Hexadecimal	0F

**Comments:** This command reverts to single width printing. Single and double width can be combined anywhere on a line.

Ex:    0E 41 41 41 41                **0F** 41 41 41 41

⇒        AA-AA-AA-AA                ⇒        AAAA

---

**UNDERLINE ON**

---

ASCII	NAK
Hexadecimal	15

**Comments:** Characters sent after this command will be underlined. Tabs are not underlined. Underlining is terminated by the U/L release command or on completion of the current line.

Ex:    41 41 41 41                    **15** 41 41 41 41  
⇒        AAAA                            ⇒        AAAA

---

**UNDERLINE OFF**

---

ASCII	CAN
Hexadecimal	18

**Comments:** This command Terminates underlining.

Ex:    15 41 41 41 41                    **18** 41 41 41 41  
⇒        AAAA                            ⇒        AAAA

---

**REVERSE PRINT**

---

ASCII	EM
Hexadecimal	19

**Comments:** This command sets the print to white on black. The command will toggle between reverse and normal print wherever it appears on a line, but the condition is always reset at the end of the line.

Ex:    41 41 41                            **19** 41 41 41  
⇒        AAA                                ⇒        **AAA**

---

**DOUBLE HEIGHT**

---

ASCII	SUB
Hexadecimal	1A

**Comments:** This command Prints the line in double height for one line only. Double height and single height cannot be mixed on the same line.

## 5.2.5 Font commands

---

### 24 COLUMNS FONT

---

ASCII	ESC
Hexadecimal	1C

**Comments:** This command selects 24 column fonts. Example: Sets 24 characters per line printing.

---

### 42 COLUMNS FONT

---

ASCII	GS
Hexadecimal	1D

**Comments:** This command selects 42 column fonts. Example: Sets 42 characters per line printing.

## 5.2.6 Graphics commands

---

### STANDARD GRAPHICS

---

ASCII	ESC <i>n</i> d1 -> d24
Hexadecimal	1B <i>n</i> d1 -> d24

**Comments:** **Standard 1000 Emulation**

Graphics command to enter bit image printing. The number of graphic bytes sent will depend on the column selection; example: 24 or 40. For each graphic byte sent, 6 bits out of the 8 bits are used to build the graphics string (LSB as the right most dot) and 'n' is the number of times the string will be repeated for a repetitive pattern. The value of 'n' is limited to a maximum of 255 lines. The print buffer will be printed first if not empty.

Examples: To repeat a string of data bytes, d1....d24 over two rows for 24 column printing send: 1BH, 02H, d1....d24.

For a non-repeated string send: 1BH, 01H, d1....d24.

**High Resolution Graphics**

To use this mode, there is an option in the set up for changing the default graphics: **HI-RES graphics**.

This works in the same manner as the standard emulation but there are 48 characters across the line, rather than 24 or 40.

**1B n d1 -> d48**

This provides full dot addressable graphics at 8 dots/mm and a true image of the data received.

---

**EPSON GRAPHICS**

---

<b>ASCII</b>	ESC K <i>n1 n2</i>
<b>Hexadecimal</b>	<b>1B 4B <i>n1 n2</i></b>

**Comments:** This command made possible by the higher resolution and memory capability of the DP1200 over the standard 1000.

The number of graphic bytes is determined by *n1* (low order byte) and *n2* (high order byte) by the equation:  $n2 + 256n1$ . For maximum graphics resolution of 384 printable positions,  $n1 = 128$  and  $n2 = 1$ . For 200 graphic bytes,  $n1 = 200$ ,  $n2 = 0$ .

**Note:**  $0 \leq n1 \leq 255$ ,  $0 \leq n2 \leq 1$ .

Each data character represents 8 dot rows of graphics, the LSB being the lowest dot. The command and data must be sent for each line of graphics

### 5.3 *Command Summary for ESC/POS Emulation (compatible WITH Epson)*

#### 5.3.1 Reset commands

---

**INITIALIZE PRINTER**

---

<b>ASCII</b>	ESC @
<b>Hexadecimal</b>	<b>1B 40</b>

**Comments:** This command initialize printer. Clears the print buffer and resets the printer mode to default values.

---

**PRINTER RESET**

---

Reboots the printer.

<b>ASCII</b>	GS (SPACE)
<b>Hexadecimal</b>	<b>1D FF</b>

## 5.3.2 Vertical positioning and print commands

### LINE FEED

---

ASCII	LF
Hexadecimal	0A

**Comments:** This command prints and moves the printing position to the beginning of the next line. If LF and CR are sent, the CR is ignored to avoid a double feed.

**Ex:** 41 41 41 41 41 0A 41 41 41  
⇒ AAAAA  
AAA

### FORM FEED

---

ASCII	FF
Hexadecimal	0C

**Comments:** This command prints the current line and feeds the number of lines determined by using the ESC C command.

### CARRIAGE RETURN

---

ASCII	CR
Hexadecimal	0D

**Comments:** This command prints the current line and feeds one line. If CR and LF are sent, the LF is ignored to avoid a double feed.

### SET LINE SPACING

---

ASCII	ESC 3 <i>n</i>
Hexadecimal	1B 33 <i>n</i>

**Comments:** This command sets the line spacing to  $n/406$  of an inch. Minimum line spacing is 7.5 lines per inch. The line equals the character height when  $n < m$  (typical  $m = 27$ ).

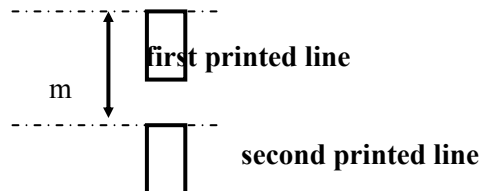

---

### SET FORM LENGTH

---

ASCII	ESC C <i>n</i>
Hexadecimal	1B 43 <i>n</i>

**Comments:** When used in conjunction with the form feed command (0Ch); the printer will feed  $n/2$  under lines. Note that if  $n = 0$  then there will be no line feeds. The default value is  $n = 0$ .

---

### PRINT & FEED

---

ASCII	ESC d <i>n</i>
Hexadecimal	1B 64 <i>n</i>

**Comments:** This command prints the data in the print buffer and performs  $n$  line feeds.

### 5.3.3 Horizontal positioning commands

---

### HORIZONTAL TAB

---

ASCII	HT
Hexadecimal	09

**Comments:** This command moves the printing position to the next horizontal tab position. Tab stops occur at every 8th column. On receipt of this command, spaces are entered into the line up to the next tab stop.

Ex:    **09** 41 41 41 41 41 41 41 41 41  
⇒        \_\_\_\_\_AAAAAAAA

---

### SET PRINT STARTING POSITION

---

ASCII	ESC \$ <i>n1 n2</i>
Hexadecimal	1B 24 <i>n1 n2</i>

**Comments:** This command sets the print starting position to the specified number of dots from the margin. The range is from 0 to 384 where  $n2$  is the high order byte ( $0 \leq n2 \leq 1$ ) and  $n1$  is the low order byte.

( $0 \leq n1 \leq 255$ ). The default condition is  $n1=n2=0$  which positions print on the left margin. The print position will always be rounded down to the nearest multiple of 8. (Example: Print position 45 will be rounded down to 40.)

### 5.3.4 Printer configuration

---

#### PRINT TEST FORM

---

This command will print the configuration settings ticket.

**ASCII**                    US t  
**Hexadecimal**        1F 74

**Note:** This command will assert busy and will ignore all input data until all tickets have been printed.

### 5.3.5 Print characteristics commands

---

#### SET PRINT MODE

---

**ASCII**                    ESC! *n*  
**Hexadecimal**        1B 21 *n*

**Comments:** This command sets the print mode according to the following table and *n* is a single byte in which each bit sets the printing function. Note that underlines cannot be used with a horizontal tab and any combination of double height and width can be used. Double and single height cannot be mixed on a line, however, whereas double and single width can be mixed anywhere on a line.

**Default is *n* = 0**

Bit	Function	Value	
		0	1
0	Character Font	16 x 24	9 x 24
1	Undefined	-	-
2	Undefined	-	-
3	Undefined	-	-
4	Double-height	Cancelled	Set
5	Double-width	Cancelled	Set
6	Undefined	-	-
7	Underline	Cancelled	Set

---

#### INVERTED PRINTING

---

**ASCII**                    ESC {*n*  
**Hexadecimal**        1B 7B *n*

**Comments:** When *n* = 1 then print is inverted and text will be printed from right to left. For normal print *n* = 0. The default mode is set by the programmed parameters in the printer.

---

**SET / CANCEL USER-DEFINED CHARACTERS**

---

ASCII            ESC % *n*  
Hexadecimal    1B 25 *n*

Range of *n*     $0 \leq n \leq 1$

**Comments:**    This sets or cancels the user defined character set.

**Note:**        Once the user defined character set has been cancelled the default character set will be loaded and the user defined characters will be lost.

0 => standard font used

1 => user-defined characters

---

**DEFINE USER-DEFINED CHARACTERS**

---

ASCII            ESC & *s n m* data  
Hexadecimal    1B 26 *s n m* data    [a[p] *s x a*]m-n+1

**Comments:**    This allows the user-defined characters to be down-loaded:

Where:

- "*s*" specifies the number of bytes in the vertical direction. **This value must be 3.**

- "*n*" specifies the beginning ASCII code for the definition and "*m*" the final code.

If only one character is defined, use  $n = m$ . **The range for *n* is  $32 \leq n \leq m \leq 255$ .**

- "*a*" specifies the number of dots in the horizontal direction.

**This value must be 16.**

- "*p*" is the dot data for the characters. The dot pattern for *a* dots in the horizontal direction from the left side.

The amount of data to be defined is  $s \times a$ .

- After user-defined characters are defined once, they are available until another definition is made or ESC % *n* is sent.

**NOTE:** See Ch "character cell structure".

The User defined character set (UDCS) and the standard character set are not available at the same time.

Normally, the UDCS will be battery backed. However, if the batteries are left to discharge completely, then the UDCS will be lost and the default character set will be loaded.

Example: (see next page)

If you want to define only the character 22h (HI-RES mode)

=> 1B 26 03 22 22 00 00 ... .. 3F 00 C0 7F 80 E0 ... ..

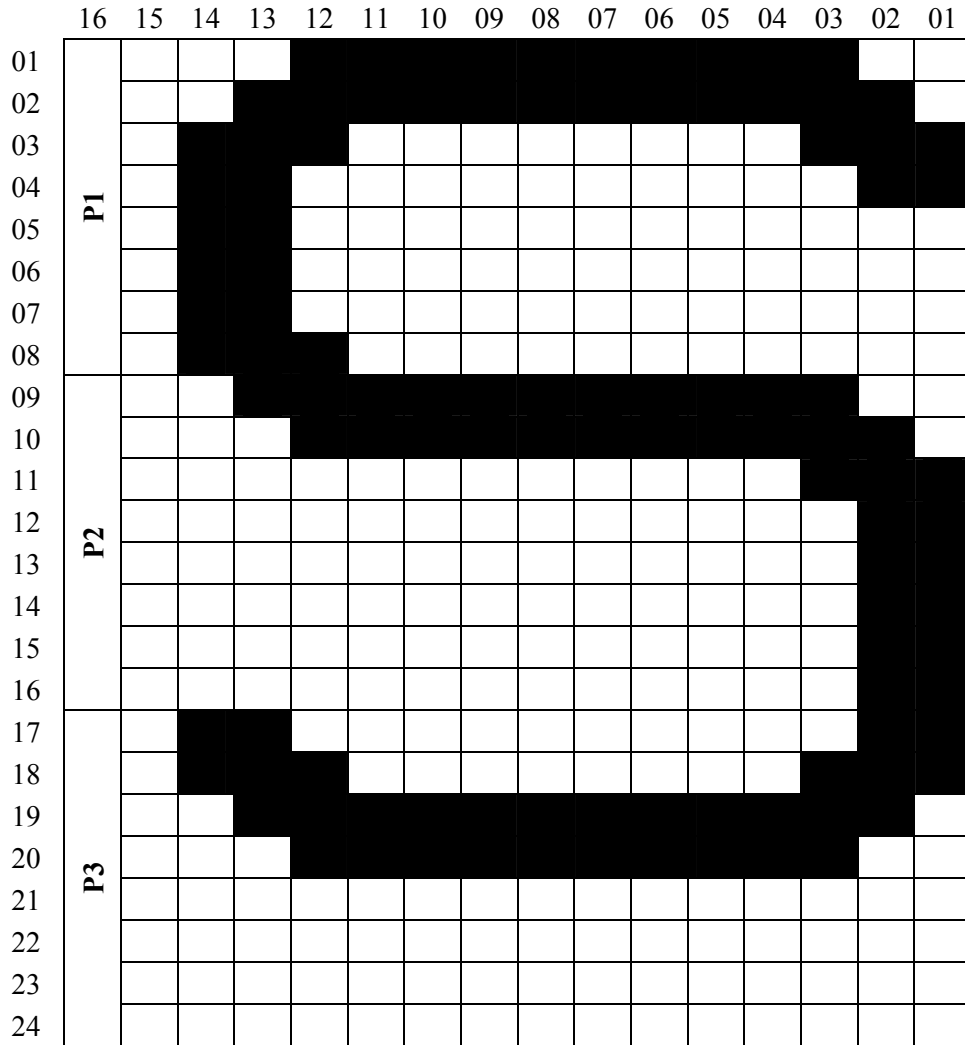

P1 = 00H	P4 = 00H	P7 = 3FH	P10 = 7FH
P2 = 00H	P5 = 00H	P8 = 00H	P11 = 80H
P3 = 00H	P6 = 00H	P9 = C0H	P12 = E0H

### Organization of a user-defined character cell

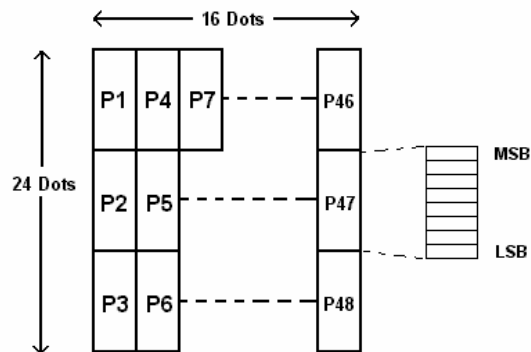

---

**SELECT INTERNATIONAL CHARACTER SET**

---

ASCII                    ESC R *n*  
Hexadecimal            1B 52 *n*

**Comments:**    The character set from the following table is determined by the value of *n*. The default value is the character set programmed in the printer.

<b>n</b>	<b>Country</b>
0	U.S.A.
1	France
2	Germany
3	U.K.
4	Denmark 1
5	Sweden
6	Italy
7	Spain
8	Japan
9	Norway
10	Denmark 2

## 5.3.7 Graphics commands

### GRAPHIC PRINTING MODE

---

**ASCII**                    DC1 n1... n1  
**Hexadecimal**        **11 n1... n1**

1	0	1	1	0	0	1	1
Black	White	Black	Black	White	White	Black	Black

MSB LSB

**Comments:** This command specifies a single line of graphic data for 384 dots, the print zone for the printer. The data is sent as 48 bytes, or 384 bits, representing the dots to be “on” or “off”.

Example:        11 0F 4C .....

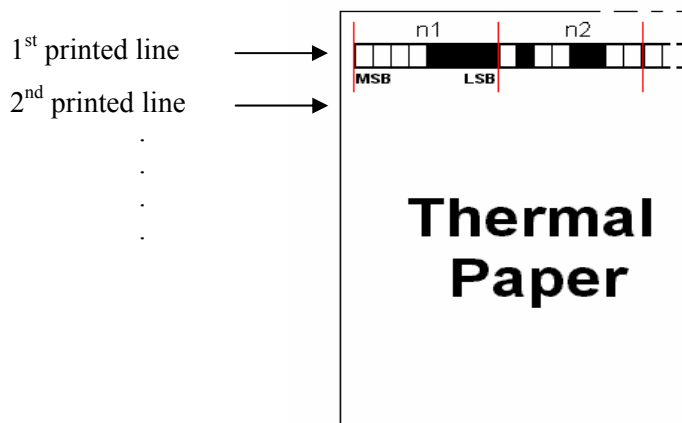

## BIT IMAGE GRAPHICS

---

**ASCII**                    ESC \* m n1 n2 data  
**Hexadecimal**            1B 2A m n1 n2 data

**Comments:**    The bit image graphics command formats and prints a bit image depending on  $m$ ,  $n1$ ,  $n2$  and the data..  
 All graphics are single density:  $m = 0$ .  
 $n1$ , and  $n2$  specify the number of bytes sent (data).  
 $n2$  is the high order byte ( $0 \leq n2 \leq 1$ ),  $n1$  is the low order byte ( $0 \leq n1 \leq 255$ ). The total number of data bits to send is calculated by the formula  $n2 \times 256 + n1$ . For 384 graphic bytes, the maximum per line, then  $n2=1$ ,  $n1=128$ . The data (d) is formatted as shown below.

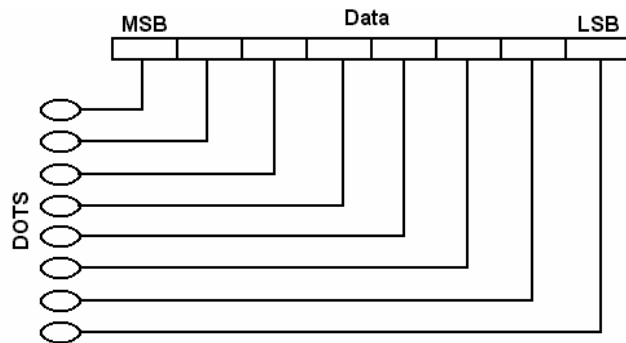

### 5.3.8 Printer Status

#### STATUS REQUEST

---

**ASCII**                    ESC v  
**Hexadecimal**            1B 76

**Comments:**    The current printer status is transmitted to the host computer on receipt of this command. It takes the form of a single byte with each bit representing a specific printer condition. The conditions indicated are “true” when the bit is logic “1”.

Bit	
0	Paper out
1	Feeding paper
2	Lid open
3	Not used
4	Not used
5	Not used
6	Not used
7	Not used

The byte is sent regardless of the CTS handshaking signal.

## RETURN SRAM SIZE

---

Returns the size of SRAM on board

**ASCII**                      **GS BS**  
**Hexadecimal**            **1D 08**

The size (in number of 64 Kbytes sectors) is returned on a single byte.

**Example:**      SRAM size = 128 Kbytes,  
the printer returns the hex value 02

## TRANSMIT PRINTER ID

---

Transmits the printer model, type of version as defined below. This command is processed as normal printer data.

**ASCII**                      **GS I n**  
**Hexadecimal**            **1D 49 n**

**Operand:**       $n =$  printer ID select  
**Limit:**          Decimal:  $n = 1; n = 49; 66 \leq n \leq 68$   
Hex:               $n = 01; n = 31; 42 \leq n \leq 44$

<b>“GS I” OPERAND AND RETURNED STATUS DEFINITION</b>				
<b>n</b>		<b>Printer ID</b>	<b>Function</b>	<b>Value (hex)</b>
<b>Decimal</b>	<b>Hex</b>			
1, 49	01, 31	Printer Model ID	A630	36
66	42	Manufacturer	AXIOHM	
67	43	Printer Name	A630 or A631	
68	44	Serial Number	Depends on serial number	

**Note:** for  $n = 66, 67, 68$  the printer response is sent back in the following format:  
Header = 5F (hex)  
Data = ASCII string  
NULL = 00 (hex)

**TRANSMIT PRINTER ID, REMOTE DIAGNOSTICS EXTENSION**

---

Performs the remote diagnostic functions specified by *n*.  
 Each returned message is defined as: *n* + data + <CR>

**ASCII**                    **GS I @ *n***  
**Hexadecimal**            **1D 49 40 *n***

**Value of *n***      Refer to table

Value of <i>n</i>		Remote diagnostic item	Function
Hex	Dec		
20	32	Serial #, 10 digit ASCII	Write to NVRAM Example, send 14 bytes to printer: GS I @ 0x20 1234567890
21	33	Serial #	Write to NVRAM, and print on receipt to verify Example, send 14 bytes to printer: GS I @ ! 1234567890 This will print on receipt: Serial # written: 1234567890
23	35	Serial #	Return Serial #, preceded by <i>n</i> to identify Printer returns 12 bytes in above example: #1234567890<CR>

## VOLTAGE AND TEMPERATURE MONITORING

---

Returns the results of latest voltage and temperature measurements.

**ASCII**                      US LF n  
**Hexadecimal**            1F 0A n

**Limit:**                  Decimal:  $132 \leq n \leq 133$   
                                 Hex:             $84 \leq n \leq 85$

Always returns 7 Bytes:  
 Command ID + zero terminated ASCII string.

<b>RETURNED STATUS DEFINITION</b>		
<i>n = 0x84: Read Voltage (in Volt)</i>		
<b>Byte</b>	<b>Function</b>	<b>Value</b>
0	Command Id	0x84
1-5	ASCII string	
6	End of String	0x00

<b>RETURNED STATUS DEFINITION</b>		
<i>n = 0x85: Read Printhead Temperature (in °C)</i>		
<b>Byte</b>	<b>Function</b>	<b>Value</b>
0	Command Id	0x85
1-5	ASCII string	
6	End of String	0x00

## SEND PRINTER SOFTWARE VERSION

---

The printer returns 8 bytes containing the boot and flash software version.  
 The first 4 bytes returned are an ASCII string for the boot version.  
 The second 4 bytes are an ASCII string for the flash version.

**Example:**            the printer returns 1.071.15  
 This means the boot version is 1.07 and the flash version is 1.15

**ASCII**                      US V  
**Hexadecimal**            1F 56

---

**SET HRI PRINT POSITION**

---

ASCII	GS H <i>n</i>
Hexadecimal	<b>1D 48 <i>n</i></b>

**Comments:** The range is  $0 \leq n \leq 3$ .  
The default value is  $n = 0$  and "n" defines the print position as follows:

$n = 0$  not printed  
 $n = 1$  above the bar code  
 $n = 2$  below the bar code  
 $n = 3$  above and below the bar code

Guard patterns are not printed in the HRI text.

---

**SELECT HRI FONT**

---

ASCII	GS f <i>n</i>
Hexadecimal	<b>1D 66 <i>n</i></b>

**Comments:** This command is used to define the size of the number under the bar code.  
The range is  $n = 0$  or 1 (**default 0**) If  $n = 0$ , the 24 column font is selected.  
If  $n = 1$ , the 40 column font is selected.

---

**SET BAR CODE HEIGHT**

---

ASCII	GS h <i>n</i>
Hexadecimal	<b>1D 68 <i>n</i></b>

**Comments:** The range is  $1 \leq n \leq 255$  and  $n$  specifies the number of dots in the bar code height.  
**Default value is  $n = 162$ .**  
Note that if  $n = 0$ , the default height is used.

## PRINT BAR CODE

---

	<u>First Variation</u>	<u>Second Variation</u>
ASCII	GS k <i>m d1...dk</i> NUL	GS k <i>m n d1...dn</i>
Hexadecimal	1D 6B <i>m d1...dk</i> NUL	1D 6B <i>m n d1...dn</i>

**Comments:** The print bar code command selects a bar code, formats the data and prints the bar code according to the variables *m*, *n* and *d*. The type of bar code is defined by “*m*” and valid values are displayed in the table below.

<i>m</i>	Bar code types	Mode
0	UPC-A *	1
1	UPC-E *	1
2	EAN13 *	1
3	EAN8 *	1
4	CODE39 **	1
5	ITF	1
6	NOT ASSIGNED	1
7	CODE128	2

*n* is the number of digits, used in mode 2 only  
*d1..dk* is the string of characters to be printed as the bar code.

\* All of these bar code types use the last character as a checksum of. For example, the UPC-A bar code needs 11 characters: the 12<sup>th</sup> is calculated automatically. If you enter 12 characters and if the 12<sup>th</sup> character doesn't correspond to the checksum of the 11 first characters, you cannot read the bar code print out.

\*\* Beginning and finishing characters are necessary: 2A ... .. 2A.

This command will always set the print position to that specified by the ESC \$ (print position) command. Certain error conditions result in data being ignored and nothing being printed, these conditions are:

- Invalid bar code type
- Invalid characters (d) in bar code
- Too many/few characters sent (UPC and EAN bar codes)
- Number of characters sent is not equal to *m*
- Bar code is wider than paper

## SET BAR CODE MAGNIFICATION

---

ASCII	GS w <i>n</i>
Hexadecimal	1D 77 <i>n</i>

**Comments:** This command selects magnification (horizontal size) of the bar code. The range is  $1 \leq n \leq 5$ .  
**The default value is *n* = 3.**  
 Note that if the bar code is too longer, no printing.

### 5.3.10 Flash Firmware Download Commands (RS232 and Bluetooth™ models only)

These commands are used to load firmware into the printer.

There are two ways to enter the download mode.

1. While the printer is running normally, send the command, “Switch to Flash Download Mode (1B 5B 7D)” to leave normal operation and enter the download mode.
2. If the Flash is found corrupted during Level 0 diagnostics the download mode is automatically entered after the printer has reset.

The printer never goes directly from the download mode to normal printer operation. To return to normal printer operation either the operator must turn the power off and then on to reboot or the application must send a command to cancel download mode and reboot.

When each flash download command is received, the printer returns either ACK or NAK to the host computer when each command is received:

ACK (hexadecimal 06)

Sent when the printer has received a host transmission and has completed the request successfully.

NAK (hexadecimal 15)

Sent when a request is unsuccessful.

The commands are listed in numerical order according to their hexadecimal codes. Each command is described and the hexadecimal, decimal, and ASCII codes are listed.

Communicates to the printer information downloaded from applications. Data is downloaded to flash memory to query the state of the firmware, calculate the firmware CRC and other functions.

#### 5.3.10.1 Firmware Download Sequence

By providing a set of low level commands, great freedom of implementation is given to customer application to customize the sequence to match its specific requirements.

Following is the description of a typical Firmware download sequence.

Only the main steps are mentioned. Error checking and error recovery is not described:

- 1) Switch to Flash Download Mode
- 2) Check Flash Memory Size
- 3) Erase all Flash Memory sectors, except Boot Sector
- 4) Download Code to Active Flash Sector
  - 4.1) Select Flash memory sector #n (each sector contains 64 Kbytes)
    - 4.1.1) Program segment of N bytes
    - 4.1.2) if more segments, loop back to 4.1.1)
  - 4.2) if more sectors to program, loop back to 4.1)
- 5) Check Flash CRC
- 6) Reboot Printer

---

**SWITCH TO FLASH DOWNLOAD MODE**

---

Puts the printer in flash download mode in preparation to receive commands controlling the downloading of objects into flash memory. When this command is received, the printer leaves normal operation and can no longer print transactions until the Reboot the Printer command (1D FF) is received or the printer is rebooted.

This command does not affect the current communication parameters. Once the printer is in flash download mode, this command is no longer available.

<b>ASCII</b>	ESC [ }
<b>Hexadecimal</b>	<b>1B 5B 7D</b>

---

**RETURN FLASH MEMORY SIZE**

---

Returns the size of the flash used. There are 4 sectors (64K each) in flash memory. This command assures that the firmware to be downloaded is the appropriate size for flash memory.

<b>ASCII</b>	GS SOH
<b>Hexadecimal</b>	<b>1D 01</b>

The returned value corresponds to the highest sector number that can be accepted by the Select Sector to Download (1D 02 *nn*) command:

03 = 256 Kbytes Flash

**Exceptions:**

Available only in download mode.

---

**SELECT FLASH MEMORY SECTOR TO DOWNLOAD**

---

Selects the flash sector (*nn*) for which the next download operation applies. The values of the possible sector are restricted, depending upon the flash part type. The printer transmits an ACK if the sector number is acceptable or an NAK if the sector number is not acceptable. Sector numbers start at 0

<b>ASCII</b>	GS STX <i>nn</i>
<b>Hexadecimal</b>	<b>1D 02 <i>nn</i></b>

**Value and Range of n**    0-3 =    256k bytes Flash

**Exceptions:**

Available only in download mode.

---

### GET FLASH FIRMWARE CRC STATUS

---

Causes the printer to calculate the CRC for the Flash firmware code space and transmits the result. This is performed normally after downloading completely a new firmware to verify that the downloaded firmware is valid

The printer transmits ACK if the calculated CRC is correct; NAK if the CRC is incorrect

<b>ASCII</b>	<b>GS ACK</b>
<b>Hexadecimal</b>	<b>1D 06</b>

---

### RETURN BOOT SECTOR CRC

---

Returns the CRC calculated over the boot sector code space.

<b>ASCII</b>	<b>GS BEL</b>
<b>Hexadecimal</b>	<b>1D 07</b>

**Formulas:**

ACK <low byte> <high byte>

---

### ERASE ALL FLASH CONTENTS EXCEPT BOOT SECTOR

---

Causes the entire flash memory to be erased.

The printer returns ACK if the command is successful; NAK if it is unsuccessful.

<b>ASCII</b>	<b>GS SO</b>
<b>Hexadecimal</b>	<b>1D 0E</b>

**Exceptions:**

Available only in download mode.

---

### RETURN MAIN PROGRAM FLASH CRC

---

Returns the CRC calculated over the flash firmware code space. The format of the response is ACK <low byte> <high byte>.

<b>ASCII</b>	<b>GS SI</b>
<b>Hexadecimal</b>	<b>1D 0F</b>

---

### ERASE SELECTED FLASH SECTOR

---

Erases the previously selected sector. The printer transmits ACK when the sector has been erased. If the previous sector is not successfully erased, or if no sector was selected, the printer transmits NAK.

**ASCII**                      GS DLE *n*  
**Hexadecimal**            **1D 10 *n***

**Value and Range of *n***                      0-3 = 256k bytes Flash

**Exceptions:** Available only in download mode.

---

### DOWNLOAD TO ACTIVE FLASH SECTOR

---

Contains a start address ( $ah \times 256 + al$ ) and count ( $ch \times 256 + cl$ ) of binary bytes to load into the selected sector, followed by that many bytes. The start address is relative to the start of the sector. Addresses run from 0 to 64K.

The printer may return one of several responses. ACK means that the data was written correctly and the host should transmit the next block. NAK means that, for some reason, the data was not written correctly. This could mean that communications failed or that the write to flash failed. The alternatives seem to be to retry the block or halt loading and assume a hardware failure.

**ASCII**                      GS DC1 *al ah cl ch d1...dn*  
**Hexadecimal**            **1D 11 *al ah cl ch d1...dn***

- Value of *al* = low byte of the address , must be even
- Value of *ah* = high byte of the address
- Value of *cl* = low byte of the count , must be even
- Value of *ch* = high byte of the count
- Value of *d* = data bytes, from 2 to *n* (always even)

<b>Value of <i>n</i> (for number of data bytes)</b>	<b>Range of Address (<i>al ah</i>)</b>	<b>Range of Count (<i>cl ch</i>)</b>
$((ch * 256) + cl)$	0000-FFFF (hexadecimal)	0002-FFFF (hexadecimal)

**Range:** Addresses run from 0 to 64K.

**Related Information:** Available only in download mode.

#### 5.3.11 Configuration commands

---

### SELECT EMULATION

---

**ASCII**                      US SOH *n*  
**Hexadecimal**            **1F 01 *n***

Comments: This command is used to select the emulation.  
*n* = 01 => ESC/POS emulation  
*n* = 00 => DP1000 emulation

Synopsis:      Setting communication parameters

**Syntax:**    **ASCII:**    US    STX    *n1*    *n2*    *n3*    *n4*    *n5*    *n6*  
                   **Hex:**        **1F**    **02**    *n1*    *n2*    *n3*    *n4*    *n5*    *n6*

Description:

<u>n1</u>	<u>Interface</u>
00h	RS232
01h	IEEE1284
04h	Bluetooth™
<u>n2, bit [0..2]</u>	<u>RS232 Baud rate</u>
00h	1200
01h	2400
02h	4800
03h	9600
04h	19200
05h	38400
06h	57600
07h	115200
<u>n2, bit 4</u>	<u>RS232 Number of stop bits</u>
0	1
1	2
<u>n2, bit 5</u>	<u>RS232 Number of data bits</u>
0	8
1	7
<u>n3</u>	<u>RS232 Parity</u>
0x00	Odd parity
0x01	Even parity
<u>n4</u>	<u>RS232 Parity mode</u>
0x00	No parity
0x01	Enabled and set using parameter described above
<u>n5</u>	<u>RS232 Handshaking</u>
0x00	Xon/Xoff
0x01	DTR/DSR
<u>n6</u>	<u>RS232 Parity Error Processing</u>
0x00	Ignore
0x01	Print '?'

- Notes:** 1) This command is processed only in boot mode.  
 If the printer is running in normal mode, send first command “switch to Boot Mode” (1B 5B 7D).
- 2) This command must be followed by “Printer Reset” command (1D FF).
- 3) Parameters n2, n3, n4, n5, n6 are ignored, if n1 = 04h (Bluetooth™), or n1 = 01h (IEEE 1284).

## PRINT DENSITY

---

Synopsis:      Setting Print density

<b>Syntax:</b>	<b>ASCII:</b>	US	VT	N	R	J	<i>n</i>
	<b>Hex:</b>	<b>1F</b>	<b>0B</b>	<b>4E</b>	<b>52</b>	<b>4A</b>	<b><i>n</i></b>
<b>Limit:</b>		<b>Decimal:</b> $70 \leq n \leq 150$					
	<b>Hex:</b>	$46 \leq n \leq 96$					

Description: Set the print density (energy applied to paper) in percent relative to nominal energy.

### WARNINGS!!

**Choose a print density setting no higher than necessary to achieve acceptable print density**  
**Failure to observe this rule may result in a printer service call**  
**Failure to observe this rule may void the printer warranty**  
**Consult your AXIOHM technical support specialist if you have questions**

## RESET EEPROM

---

Synopsis:      Reset EEPROM

<b>Syntax:</b>	<b>ASCII:</b>	US	CR	C	L	E	<i>n</i>
	<b>Hex:</b>	<b>1F</b>	<b>0D</b>	<b>43</b>	<b>4C</b>	<b>45</b>	<b><i>n</i></b>
<b>Operand:</b>		<i>n</i> = security byte					
<b>Limit:</b>		<i>n</i> = 0					

Description:    This command will reset the non-volatile memory configuration items to their default values.

### **Notes:**

- This command must be sent while the printer is in its normal operating mode.
- Once the configuration parameters are downloaded to the printer using this command, the printer must be reset before they take effect.
- Disabling the knife is not an option when a presenter is selected.

RESET EEPROM		
OPERAND DEFINITION		
<i>n</i>		Reset
Decimal	Hex	
0	00	Reset EEPROM

## 6 STANDARD AND INTERNATIONAL CHARACTER SET

### 6.1 Standard: Code Page 437 (modified with euro character at position D5)

00	10	20	30	40	50	60	70	80	90	A0	B0	C0	D0	E0	F0
		SP	0	@	P	,	p	Ç	É	á	⋮	⌒	⌒	∞	≡
0	16	32	48	64	80	96	112	128	144	160	176	192	208	224	240
01	11	21	31	41	51	61	71	81	91	A1	B1	C1	D1	E1	F1
		!	1	A	Q	a	q	ü	æ	í	⋮	⊥	⌒	β	±
1	17	33	49	65	81	97	113	129	145	161	177	193	209	225	241
02	12	22	32	42	52	62	72	82	92	A2	B2	C2	D2	E2	F2
		"	2	B	R	b	r	é	Æ	ó	⋮	⊥	⌒	Γ	≥
2	18	34	50	66	82	98	114	130	146	162	178	194	210	226	242
03	13	23	33	43	53	63	73	83	93	A3	B3	C3	D3	E3	F3
		#	3	C	S	c	s	â	ô	ú		⊥	⌒	π	≤
3	19	35	51	67	83	99	115	131	147	163	179	195	211	227	243
04	14	24	34	44	54	64	74	84	94	A4	B4	C4	D4	E4	F4
		\$	4	D	T	d	t	ä	ö	ñ	⊥	⊥	⌒	Σ	∫
4	20	36	52	68	84	100	116	132	148	164	180	196	212	228	244
05	15	25	35	45	55	65	75	85	95	A5	B5	C5	D5	E5	F5
		%	5	E	U	e	u	à	ò	Ñ	⊥	⊥	€	σ	J
5	21	37	53	69	85	101	117	133	149	165	181	197	213	229	245
06	16	26	36	46	56	66	76	86	96	A6	B6	C6	D6	E6	F6
		&	6	F	V	f	v	â	û	a	⊥	⊥	⌒	μ	÷
6	22	38	54	70	86	103	118	134	150	166	182	198	214	230	246
07	17	27	37	47	57	67	77	87	97	A7	B7	C7	D7	E7	F7
		'	7	G	W	g	w	ç	ù	o	⊥	⊥	⊥	τ	≈
7	23	39	55	71	87	103	119	135	151	167	183	199	215	231	247
08	18	28	38	48	58	68	78	88	98	A8	B8	C8	D8	E8	F8
		(	8	H	X	h	x	ê	ÿ	¿	⊥	⌒	⊥	φ	°
8	24	40	56	72	88	104	120	136	152	168	184	200	216	232	248
09	19	29	39	49	59	69	79	89	99	A9	B9	C9	D9	E9	F9
		)	9	I	Y	i	y	ë	Ö	⌒	⊥	⊥	⊥	⊖	•
9	25	41	57	73	89	105	121	137	153	169	185	201	217	233	249
0A	1A	2A	3A	4A	5A	6A	7A	8A	9A	AA	BA	CA	DA	EA	FA
		*	:	J	Z	j	z	è	Ü	⌒	⊥	⊥	⌒	Ω	•
10	26	42	58	74	90	106	122	138	154	170	186	202	218	234	250
0B	1B	2B	3B	4B	5B	6B	7B	8B	9B	AB	BB	CB	DB	EB	FB
		+	;	K	[	k	{	ï	¢	½	⊥	⊥	■	δ	√
11	27	43	59	75	91	107	123	139	155	171	187	203	219	235	251
0C	1C	2C	3C	4C	5C	6C	7C	8C	9C	AC	BC	CC	DC	EC	FC
		,	<	L	\	l		î	£	¼	⊥	⊥	■	∞	ñ
12	28	44	60	76	92	108	124	140	156	172	188	204	220	236	252
0D	1D	2D	3D	4D	5D	6D	7D	8D	9D	AD	BD	CD	DD	ED	FD
		-	=	M	]	m	}	ì	¥	ì	⊥	=	■	∅	²
13	29	45	61	77	93	109	125	141	157	173	189	205	221	237	253
0E	1E	2E	3E	4E	5E	6E	7E	8E	9E	AE	BE	CE	DE	EE	FE
		.	>	N	^	n	~	Ä	Pt	«	⊥	⊥	■	ε	■
14	30	46	62	78	94	110	126	142	158	174	190	206	222	238	254
0F	1F	2F	3F	4F	5F	6F	7F	8F	9F	AF	BF	CF	DF	EF	FF
		/	?	O	_	o	△	À	f	»	⊥	⊥	■	∩	BLANK
15	31	47	63	79	95	111	127	143	159	175	191	207	223	239	255

## 6.2 Additional codes

	n	35D 23H	36D 24H	64D 40H	91D 5BH	92D 5CH	93D 5DH	94D 5EH	96D 60H	123D 7BH	124D 7CH	125D 7DH	126D 7EH
U.S.A.	0	#	\$	@		\		^	`	{		}	~
France	1	#	\$	a	°	ç	§	^	`	é	ù	è	"
Germany	2	#	\$	§	Ä	Ö	Ü	^	`	a	ö	ü	ß
U.K.	3	£	\$	@		\		^	`	{		}	~
Denmark 1	4	#	\$	@	Æ	Ø	Å	^	`	æ	ø	å	~
Sweden	5	#	¤	é	Ä	Ö	Å	Ü	é	ä	ö	å	ü
Italy	6	#	\$	@	°	\	é	^	ù	à	ò	è	i
Spain	7	Pt	\$	@	i	Ñ	¿	^	`	"	ñ	}	~
Japan	8	#	\$	@		¥		^	`	{		}	~
Norway	9	#	¤	é	Æ	Ø	Å	Ü	é	æ	ø	å	ü
Denmark 2	10	#	¤	é	Æ	Ø	Å	Ü	é	æ	ø	å	ü

## 7 TROUBLE SHOOTING

AXIOHM printers are simple and generally trouble-free, but from time to time minor problems may occur. Follow these procedures to determine the cause and resolution of any problems the printer may be having. If the procedures in this section do not correct the problem, contact a service representative.

### 7.1 Problems and solutions

Lights are "off" when powered	Check the battery and cables connections.	/
Lights are continuously "on", but printer does not operate	Check to see if the interface cable is well connected.	/
The red light is flashing slowly	The printer is in boot mode, meaning that the main firmware could be corrupted.  Try to reset the printer. If the red LED keeps flashing, the main firmware needs to be downloaded.  Contact your distributor or AXIOHM's Technical Support team.	/
The red light is flashing quickly	Check that cover is well closed, if not close it.  Open the cover and make sure there is paper left in the printer, if not: remove the paper roll core, place a new paper roll.  Open the cover and check there is no paper jam, if there is some: unwind the paper until no wrinkle appears, close the cover with wrinkled part out and cut it with the tear bar.	/
The green light is flashing slowly	The battery is low.  Connect the power supply to charge the battery	<b>A631 only</b>
Printing quality is deteriorating	The print-head may be getting dirty, see next chapter.	/
The interface board configuration doesn't match the daughter board assembly : BT daughter board, RS232 configuration and vice versa	Check that the interface board configuration showed on the diagnostics form matches the daughter board assembly.  In case of mismatch, follow this 2 steps sequence to toggle interface configuration between RS232 and Bluetooth™.  1/ Switch to boot mode: open the cover and reset the printer while holding down the paper feed button.  The RED LED should blink slowly.  2/ Release the paper feed button and hold it down again for at least 10 seconds.	/
Charging does not begin	Charging is possible only if the battery is low (the green light must flash slowly)	<b>A631 only</b>

### Further details to solve eventual problems

<p><b>If the print looks squashed</b></p>	<p>Check that the paper roll is sitting correctly in the paper well and that the roll is the right way up. The paper should be feeding off the bottom of the roll into the back of the mechanism NOT off the top of the roll. Remove paper and reload if necessary.</p>
<p><b>The printer prints “?” “!” or “*” in place of the transmitted characters or it does not action commands.</b></p>	<p>Check the handshaking line, parity setting and baud-rate. The different characters denote particular errors: “?” - parity error, “!” - framing error, “*” - over run error.</p>
<p><i>Note 1:</i> in any case make sure you use thermal sensitive paper and that the paper roll is well set in its bucket. Check that the sensitive layer of the paper is on the print-head side</p>	
<p><i>Note 2:</i> when resetting the printer, every running operation is stopped and all information sent before resetting is lost.</p>	

## 8 CLEANING YOUR PRINTER

The A630/A631 printer is a highly reliable unit, which requires very little maintenance but will benefit from cleaning as described in the next sections.

**Before cleaning, unplug all electrical connections.**

### 8.1 *Cleaning the printer*

Keep the external surfaces clean by wiping with a lightly damp cloth. Make sure that the inside surfaces are kept dry at all times, and that the external surfaces are thoroughly dry before re-connecting.

### 8.2 *Cleaning the print head*

Depending of the environment in which the printer is used, the print head may accumulate dust. Therefore it is necessary to clean it periodically in order to maintain a good print quality. The cleaning period depends on the environment and the usage of the printer, but it should be cleaned at least once a year or up to once a month in heavy-duty applications. The print head should always be cleaned immediately if the print becomes visibly fainter due to contamination of the print head.

**To clean the print head:**

Switch the printer off.

**Never clean the head immediately after printing, it may still be hot.**

Open the cover of the printer and remove the roll of paper.

Clean the heating dots of the head with a cotton stick and a little alcohol solvent (ethanol, methanol or IPA), but **do not touch the print head with you fingers!**

Allow the solvent to dry

Reload the paper and close the cover

*Note:* AXIOHM can also provide you with cleaning kits: reference n° CK60000A.

## 9 WARRANTY

The printers or spare parts are guaranteed for a period of twelve (12) months, beginning at the delivery date (ex-works).

The printers are guaranteed against defective material and/or workmanship. The warranty covers only, and at AXIOHM's choice, the cost of repair or replacement by AXIOHM in its factory, after restitution by the customer of the printers or spare parts confirmed by AXIOHM to be defective (*excluding assembling, dismounting, shipping and other expenses*).

The implementation of the warranty will not extend the warranty period.

Due to the complexity of the electronic and mechanical techniques used in the operation of such a printer, AXIOHM does not warranty problems resulting from an installation not according to the published specifications.

This warranty is subject to strict compliance with AXIOHM's technical instructions for installation, use and maintenance.

In particular, this warranty will not be valid for any defects due to:

- Use of thermal paper other than those recommended by AXIOHM.
- Incorrect maintenance.
- Defective installation or modification not approved by AXIOHM.
- Non-compliance, during any period, with the specified working conditions including the electrical power supply specifications.
- Abnormal wear or mechanical damage, including dot burning due to power overloads.
- Transportation in packaging other than the type of carton / foam insert in which the printer was originally packed.
- Any transportation, storage or setting up which does not comply with the technical specifications given to the customer by AXIOHM, or its official distributor, will invalidate this warranty.

In no event shall AXIOHM assume any liability in excess of that defined above. It is agreed that AXIOHM will not be liable for any indemnity for accidents to persons, damage to property or for loss of earnings.

## 10 ACCESSORIES

Reference	Designation	Contents
<b>3105338</b> <i>For Products:</i>	<b>RS232 INTERFACE CABLE A631</b> All A631	<i>Lot of:</i> RS232 interface cable (x1)
<b>A3107756</b> <i>For Products:</i>	<b>CARRY CASING</b> All A631	<i>Lot of:</i> Carry Casing (x1)
<i>* See chapter "Description of printer parts"</i>		
<b>3106880</b> <i>For Products:</i>	<b>BATTERY A631</b> All A631	<i>Lot of:</i> NiCd battery (x21)
<b>A3107861</b> <i>For Products:</i>	<b>BLUETOOTH USB DONGLE with installation CD (range: 100m)</b> All A631 Bluetooth	<i>Lot of:</i> (x1)