

UCH100 Series

SPECIFICATIONS

FOR

Magnetic Stripe Card Reader

Manual Swipe type/TTL Output Signal

UDN PM043
Revision A

CONTENTS

1. INTRODUCTION	2
2. FEATURES	2
3. GENERAL SPECIFICATION	2
3.1 FUNCTION.....	2
3.2 GENERAL CHARACTERISTICS	3
3.3 ENVIRONMENT CHARACTERISTICS.....	3
3.4 SERVICE LIFE AND ERROR RATE (CONTINUOUS TESTED IN INDOOR LAB. CONDITION).....	3
3.5 CARD STANDARD INFORMATION	3
4. OUTPUT CHARACTERISTICS	4
5. TIMING DIAGRAM	5
6. PIN ASSIGNMENT	6
7. MODEL DESCRIPTION	6
8. OUTLINE DIMENSION	7

Warranty:

For defects occur due to improper material or workmanship within 1 year after delivery of the unit, the defective parts shall be replaced or return to repaired free of charge. Any alter or erase of date code or modify of the unit, this warranty will be expired immediately.

1. INTRODUCTION

This specification describes the UCH100 Series Magnetic Stripe Card Reader, which reads magnetically encoded data on a magnetic stripe card conforming to ISO 7811.

2. FEATURES

- ◆ Manual Swipe operation
- ◆ Available both 3.3V and 5.0V operating condition
- ◆ Read both low and high Coercivity card (300~4000 Oe)
- ◆ Small compact size, light weight
- ◆ High Performance
- ◆ High Reliability
- ◆ Dual and triple track model

3. GENERAL SPECIFICATION

3.1 FUNCTION

- a. Card Reading : Bi-Direction
- b. Read / Write : Read only
- c. Card Operating speed :

TEST CARD/SPEED	
Test Card	Speed (inch/sec.)
Normal	5 - 55 ips
Jitter	5 - 50 ips
Low Amplitude	5 - 50 ips

- ◆ Test card thickness is 0.76mm +/- 0.08mm (0.030" +/- 0.003")
 - ◆ Reliable to read Jitter card of magnetic stripes encoded with bit cell length variations within +/-15% as defined in ISO 7811
 - ◆ Reliable to read Low Amplitude card of magnetic stripes encoded at 60% or more of the amplitude as defined in ISO 7811
- d. Output signal level : TTL, RCP & CLS at Negative logic.
- e. Output signal timing : RCP width approx. 60uS, see 5.Timing Diagram for the detail.

3.2 GENERAL CHARACTERISTICS

- a. Size : 48X12.2X12.9mm
 b. Weight : Approx. 10g
 c. Power required :

	Triple Track	
Voltage	3.3V DC (3.0V~3.6V)	5.0V DC (4.5V~5.5V)
Consumption	2.5mA max.	3.5mA max.
Ripple	65mVp-p	100mVp-p

- d. Dielectric strength : DC 250V for 1 minute (PCB ground to mounting screws)
 e. Insulation resistance : 10M Ohm Min. at DC 250V (PCB ground to mounting screws)

3.3 ENVIRONMENT CHARACTERISTICS

- a. Operation Temperature : -35 ~ 70°C
 b. Storage Temperature : -30 ~ 70°C
 c. Operating Humidity : 10 ~ 90% RH
 d. Storage Humidity : 10 ~ 90% RH
 e. Vibration : 10 to 50 Hz, 2mm full amplitude in x, y, z directions,
 respectively for 30 minutes.
 f. Shock durability : 30G

3.4 SERVICE LIFE AND ERROR RATE (Continuous tested in indoor Lab. Condition)

- a. Life of head : Approx. 500,000 passes under normal ideal Lab. environment.
 b. Error rate : Less than 0.5% under normal ideal Lab. environment.
 c. MTBF > 1,00,000 Hours

3.5 CARD STANDARD INFORMATION

Card Standard	IATA	ABA	THRIFT
Tracks	Track 1	Track 2	Track 3
Encoding Method	F2F (FM)	F2F (FM)	F2F (FM)
Encoding Density	210 BPI	75 BPI	210 BPI
Character Capacity	79 Characters (7-bit code)	40 Characters (5-bit code)	107 Characters (5-bit code)

IATA : International Air Transportation Association Standard

ABA : American Banker Association Standard

THRIFT : Thrift Industry Standard

- ◆ We reserve the right for modification to improve performance once the modification will have no effect to exist user's system.

4. OUTPUT CHARACTERISTICS

● VCC=5.0V

Symbol	Parameter	Conditions	Ratings			Unit
			Min.	Typ.	Max.	
IOH	Output High Source Current at VOH=VCC-0.4V	RCP, RDP	1.0	1.5	2.0	mA
IOH	Output High Source Current at VOH=VCC-0.4V	CLS	4.0	8.0	12.0	uA
IOL	Output Low Sink Current at VOL=0.4V	RCP, RDP, CLS	2.5	3.5	5.0	mA

● VCC=3.3V

Symbol	Parameter	Conditions	Ratings			Unit
			Min.	Typ.	Max.	
IOH	Output High Source Current at VOH=VCC-0.4V	RCP, RDP	0.3	0.6	1.0	mA
IOH	Output High Source Current at VOH=VCC-0.4V	CLS	2.0	4.0	6.0	uA
IOL	Output Low Sink Current at VOL=0.4V	RCP, RDP, CLS	0.8	1.5	2.5	mA

5. TIMING DIAGRAM

TIMING DIAGRAM

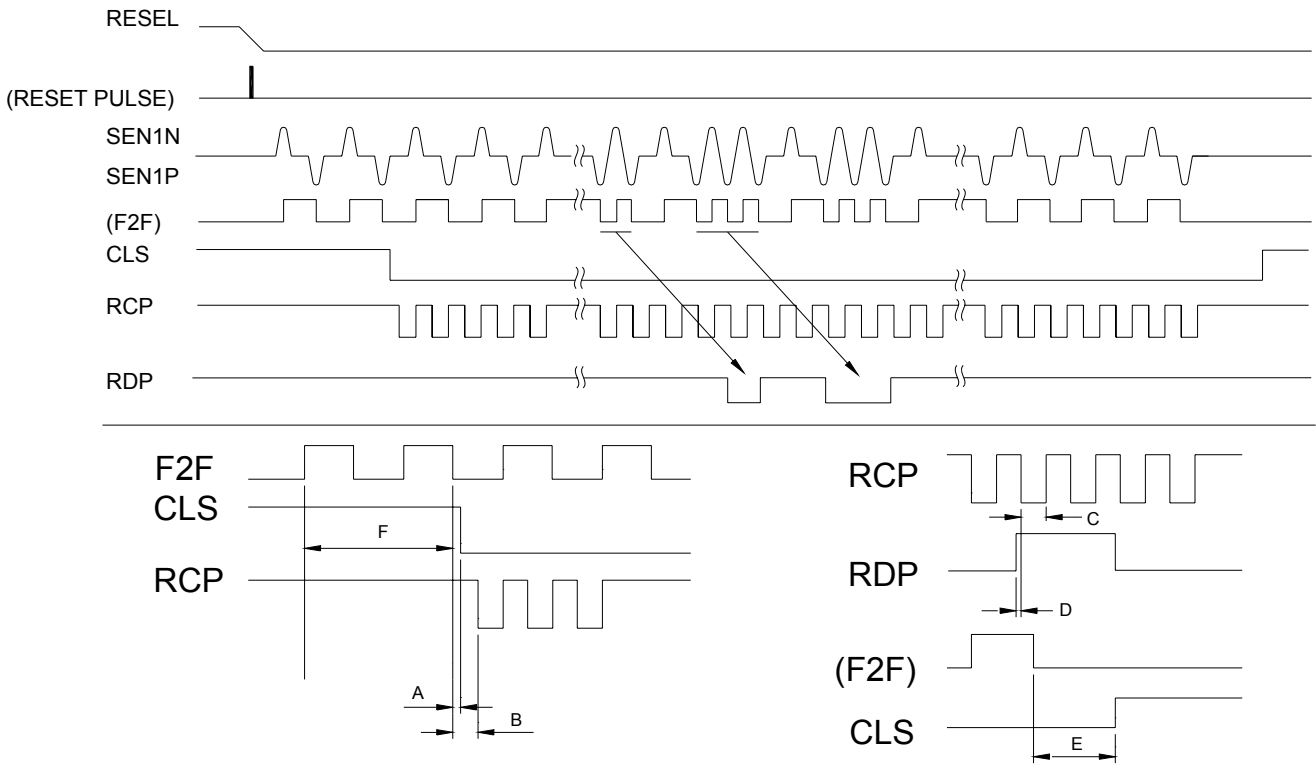

Remarks: Time width of the A, B, C, D, E, F:

A: Approximate 1~2uS

B: The 1st RCP occur at the 12th or 13th F2F signal reversal, dependent on data 0 or 1 starting at the 11th F2F signal reversal

C: Adjustable from 7uS~68uS

D: Approximate 1.75uS

E: Approximate 7.7uS

F: CLS goes Low after the 12th F2F signal reversal

6. PIN ASSIGNMENT

PIN Assignment				
Pin	Wires Color	Dual Track 1&2	Dual Track 2&3	Triple Track 1,2,3
1	BLACK	GND	GND	GND
2	BROWN	/RCP2	/RCP2	/RCP2
3	RED	/RDP2	/RDP2	/RDP2
4	ORANGE	CLS	CLS	CLS
5	YELLOW	/RCP1	/RCP3	/RCP1
6	GREEN	/RDP1	/RDP3	/RDP1
7	BLUE	CLS	CLS	CLS
8	PURPLE	VCC	VCC	VCC
9	GRAY	--	--	/RCP3
10	WHITE	--	--	/RDP3

1. The pin-out assumes that the track two magnetic stripe & the spring mounting hole centerlines are the same.
2. The centerlines should be the same as assumed as in Note 1 and track 1 or 3 outputs are available are available by turning the head 180 degrees.

7. MODEL DESCRIPTION

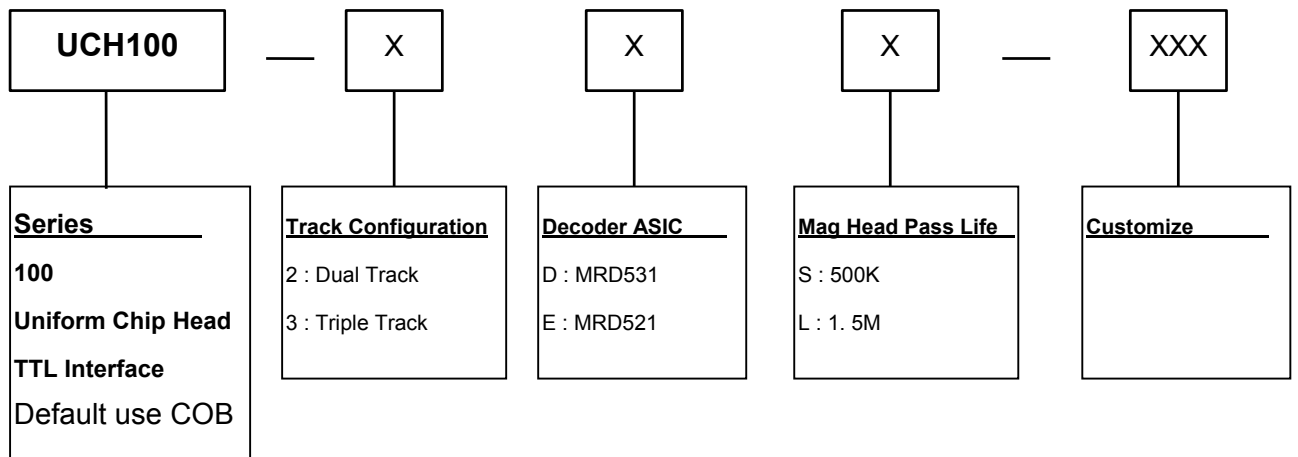

8. WIRE ASS'Y DRAWING

● Triple Track

HOUSING PIN NO	1	2	3	4	5	6	7	8	9	10
WIRES COLOR	BLACK	BROWN	RED	ORANGE	YELLOW	GREEN	BLUE	PURPLE	GRAY	WHITE
SIGNAL NAME	GND	RCP2	RDP2	CLS	RCPT	RDPT	CLS	Vcc	RCP3	RDP3
UIC PCBA SIGNAL	3	6	7	10	4	5	11	2	8	9
COB PCBA SIGNAL	2	8	7	4	10	9	11	3	6	5

TABLE "A"

NOTES:
 1 .CONNECTOR:
 HOUSING : 10 PIN, STYLE ZHR-10P
 CRIMP TERMINAL: PER SZH-003T-P0.5
 THE SAME PARTS OR EQUIVALENT
 PULL TEST FORCE(1b): 1.0(b) 1 MINUTE (SEE ATTACHED)
 2 .WIRES: UL1571 32 AWG OD=0.60mm(REF)X10
 COLORS PER TABLE "A"

REV.	DATE	REC NO	DESCRIPTION	DRAWING BY	APPR. BY	APP. JASON-Hsieh	DATE 7/01/03
B	92.12.24		ADD SIGNAL FOR COB	Sophy Lee			
A	92.7.11	162ECO01	NEW RELEASE	Sophy Lee	蘇雅華		

REV.	DATE	REC NO	DESCRIPTION	DRAWING BY	APPR. BY	APP. JASON-Hsieh	DATE 7/01/03
B	92.12.24		ADD SIGNAL FOR COB	Sophy Lee			
A	92.7.11	162ECO01	NEW RELEASE	Sophy Lee	蘇雅華		

● Dual Track

HOUSING PIN NO	1	2	3	4	5	6	7	8
WIRES COLOR	BLACK	BROWN	RED	ORANGE	YELLOW	GREEN	BLUE	PURPLE
SIGNAL NAME	GND	RCP2	RDP2	CLS	RCPT/3	RDPT/3	CLS	Vcc
UIC PCBA SIGNAL	3	6	7	10	4	5	11	2
COB PCBA SIGNAL	2	8	7	4	10	9	11	3

TABLE "A"

NOTES:
 1 .CONNECTOR:
 HOUSING : 10 PIN, STYLE ZHR-8P
 CRIMP TERMINAL: PER SZH-003T-P0.5
 THE SAME PARTS OR EQUIVALENT
 PULL TEST FORCE(1b): 1.0(b) 1 MINUTE (SEE ATTACHED)
 2 .WIRES: UL1571 32 AWG OD=0.60mm(REF)X10
 COLORS PER TABLE "A"

REV.	DATE	REC NO	DESCRIPTION	DRAWING BY	APPR. BY	APP. JASON-Hsieh	DATE 7/01/03
B	92.12.24		ADD SIGNAL FOR COB	Sophy Lee			
A	92.10.21	162ECO02	NEW RELEASE	Sophy Lee	蘇雅華		

REV.	DATE	REC NO	DESCRIPTION	DRAWING BY	APPR. BY	APP. JASON-Hsieh	DATE 7/01/03
B	92.12.24		ADD SIGNAL FOR COB	Sophy Lee			
A	92.10.21	162ECO02	NEW RELEASE	Sophy Lee	蘇雅華		

9. OUTLINE DIMENSION

- Triple Track

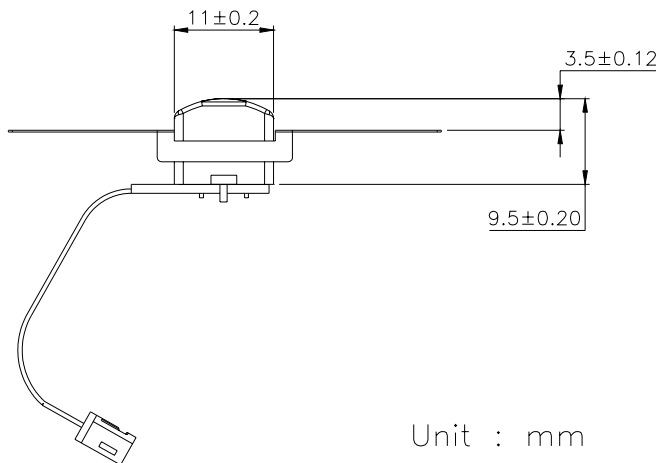
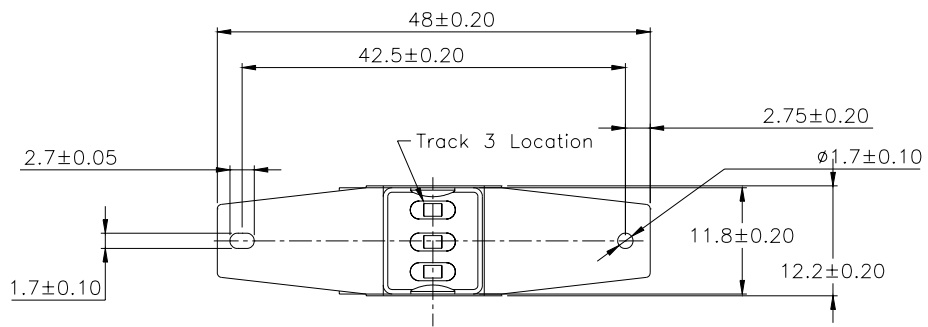
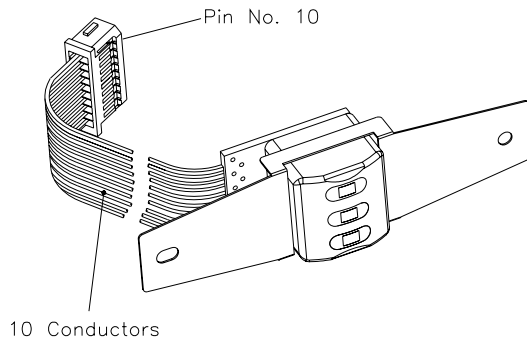

Unit : mm

● Dual Track

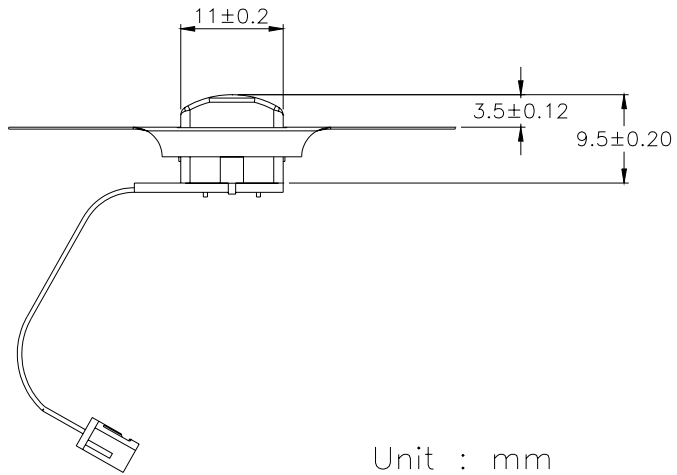
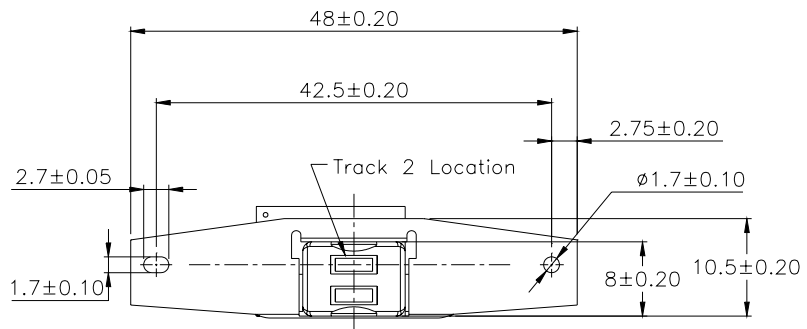
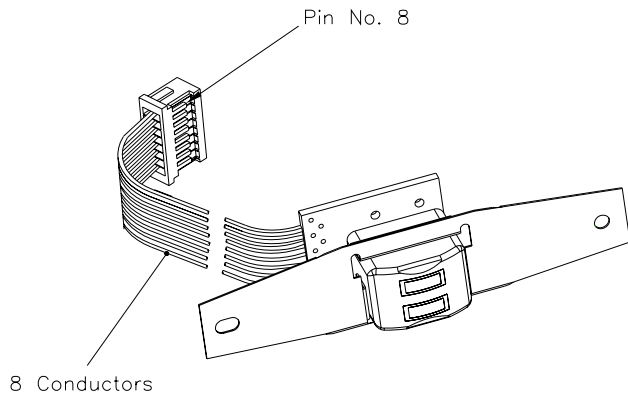

Unit : mm

10. RECOMMEND MOUNTING DIMENSION

- Triple Track

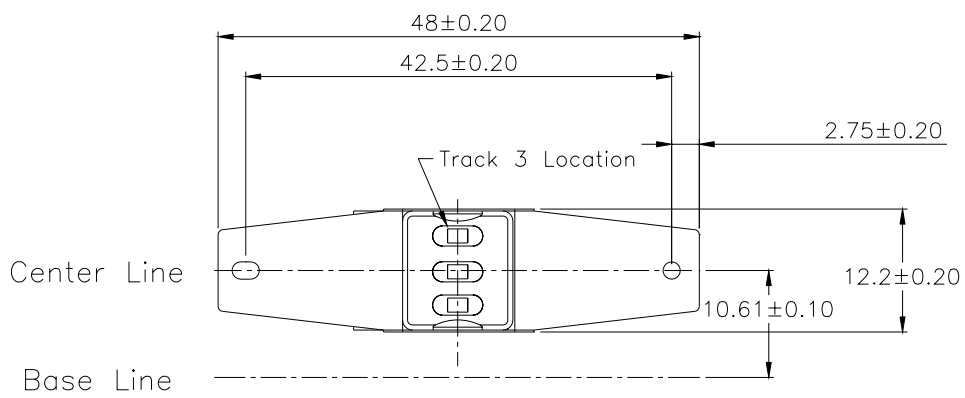

Unit : mm

- **Dual Track (1&2)**

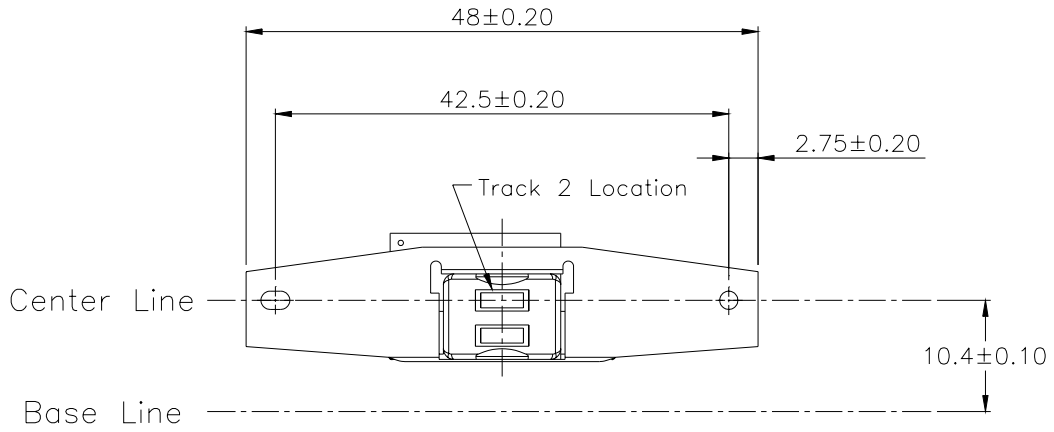

Unit : mm

- **Dual Track (2&3)**

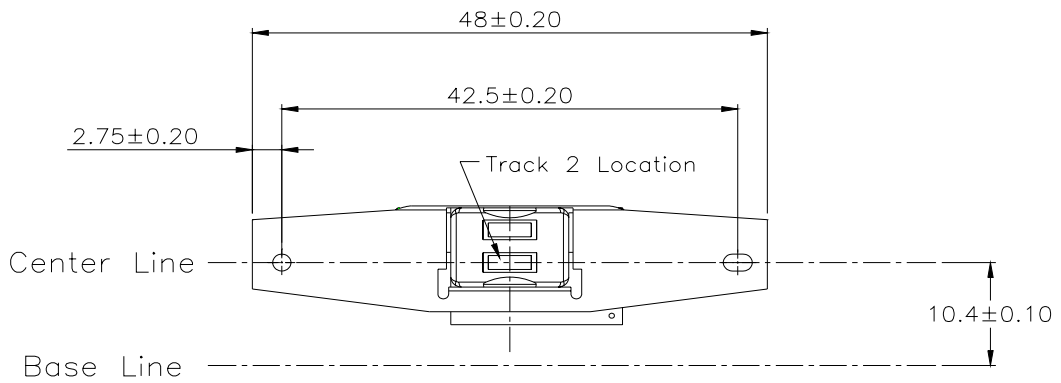

Unit : mm